

Be sure to choose 'actual size' when printing from adobe reader; make sure to disable any scaling effects from the printing options

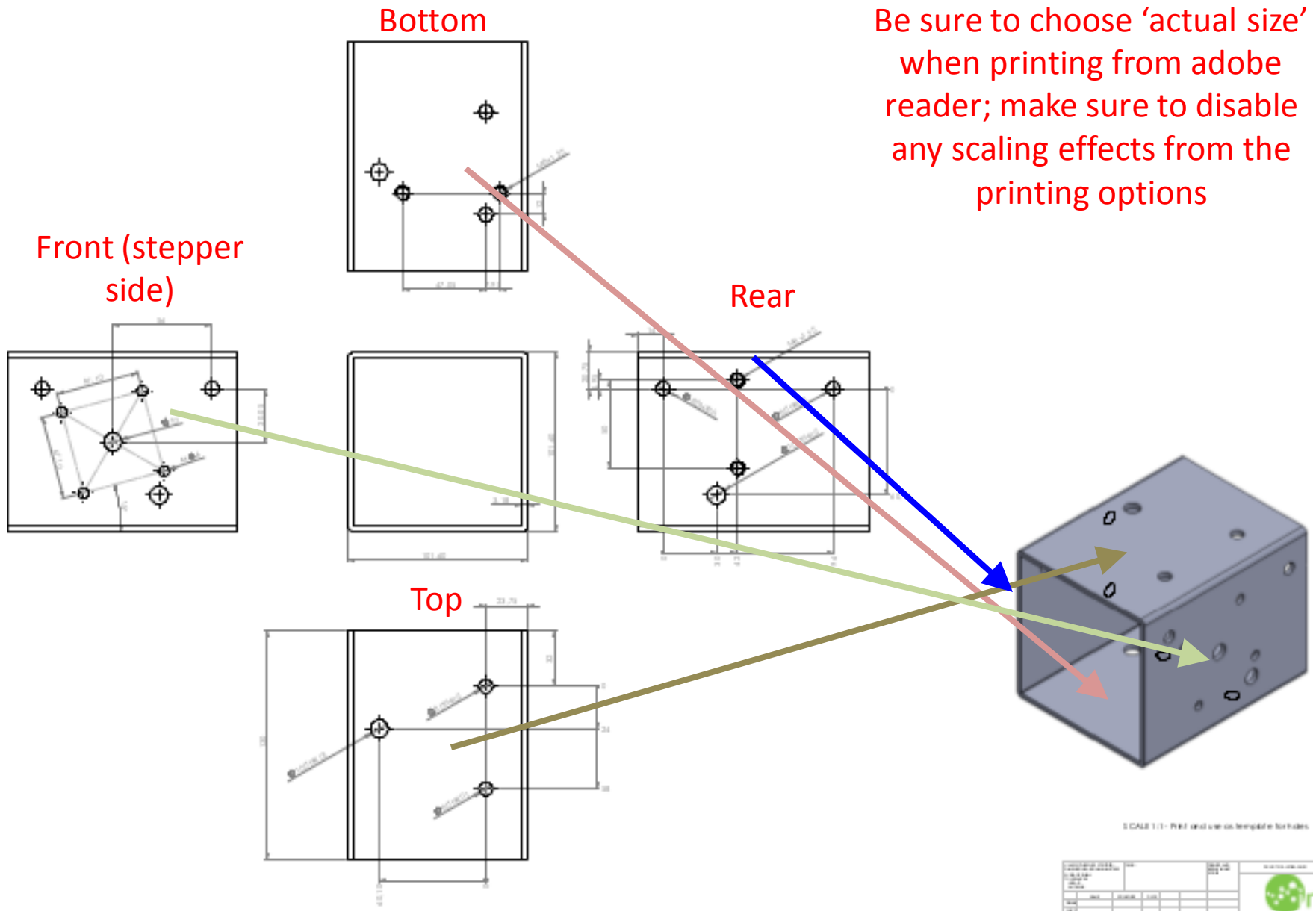

Beam Short X0, Y1, Y2 front (stepper side) - Imperial

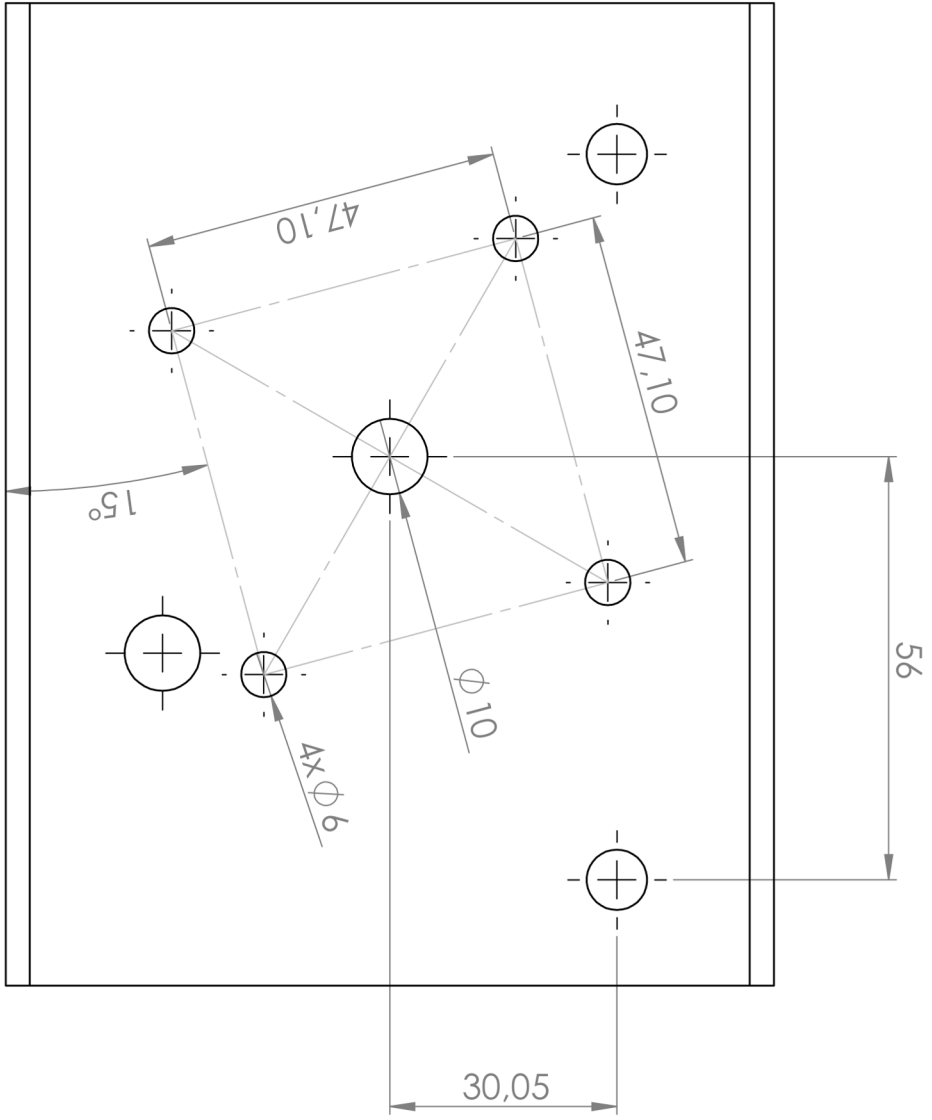

Beam Short X0, Y1, Y2 rear - Imperial

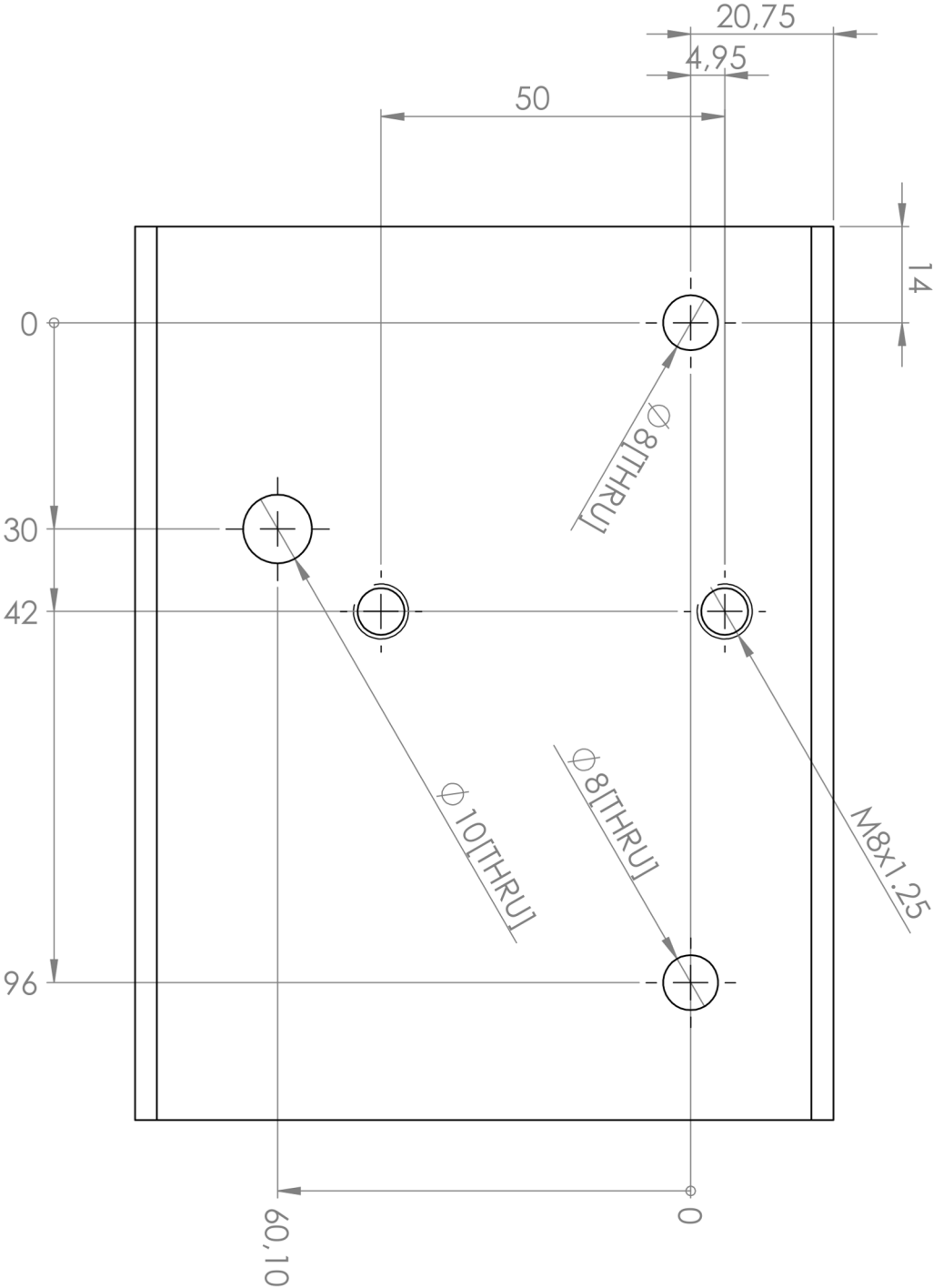

Beam Short X0, Y1, Y2 bottom - Imperial

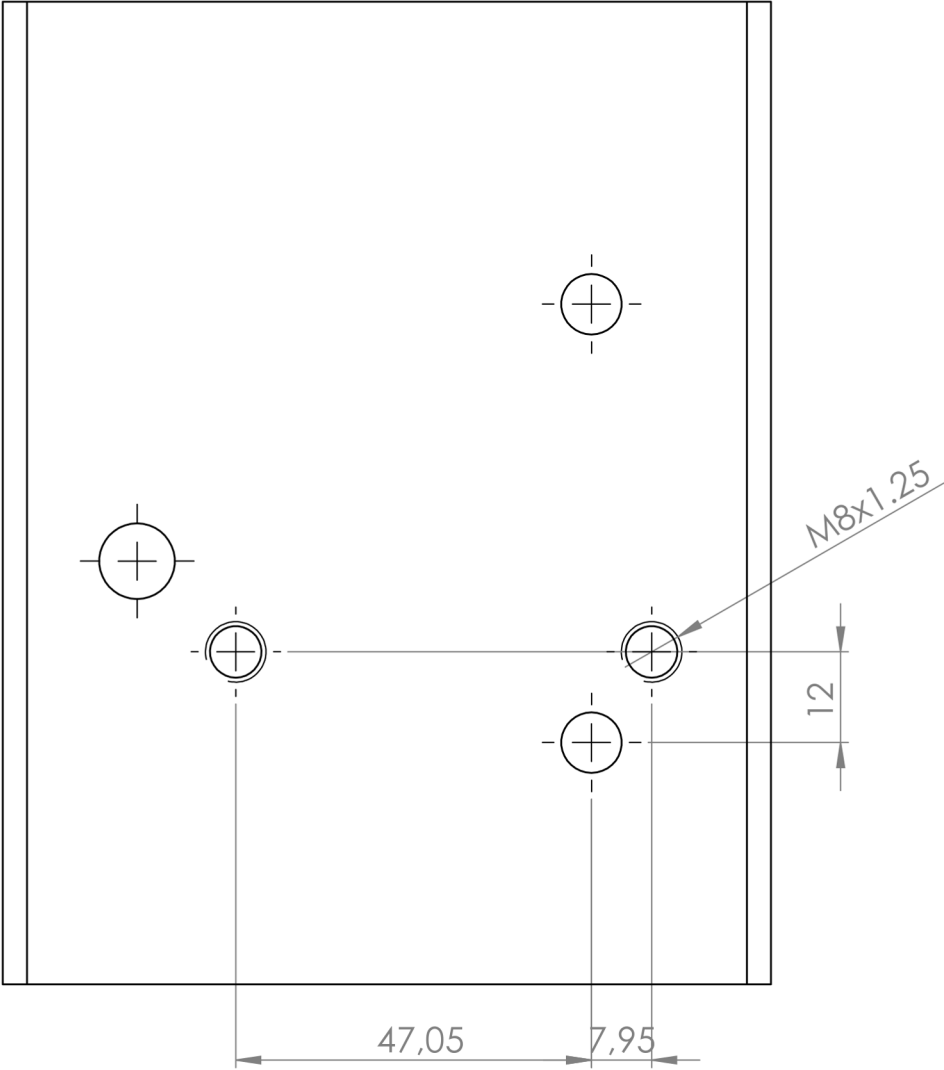

Beam Short X0 top - Imperial

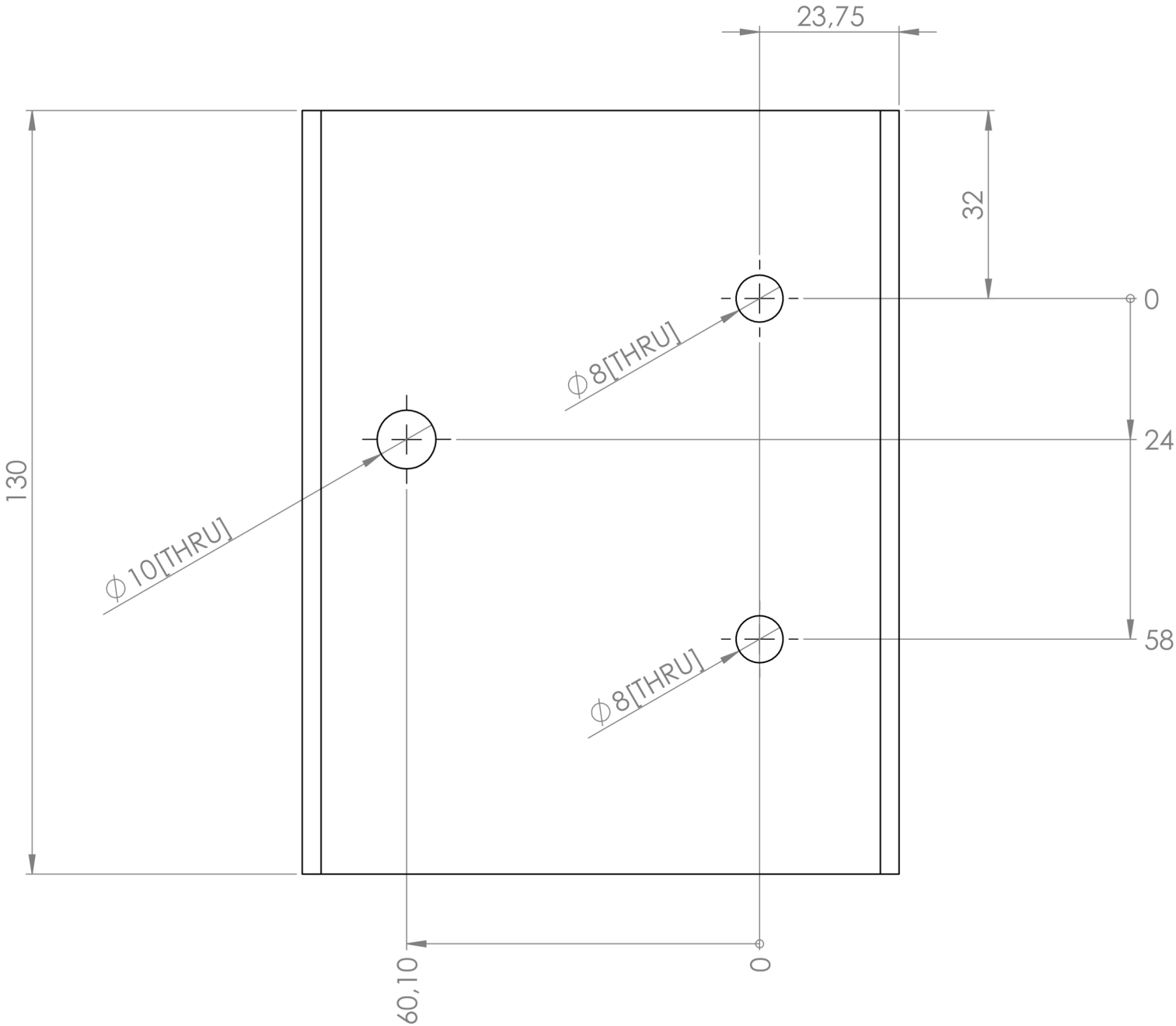

Beam Short Y1 top - Imperial

Extra hole on top for X axis mount

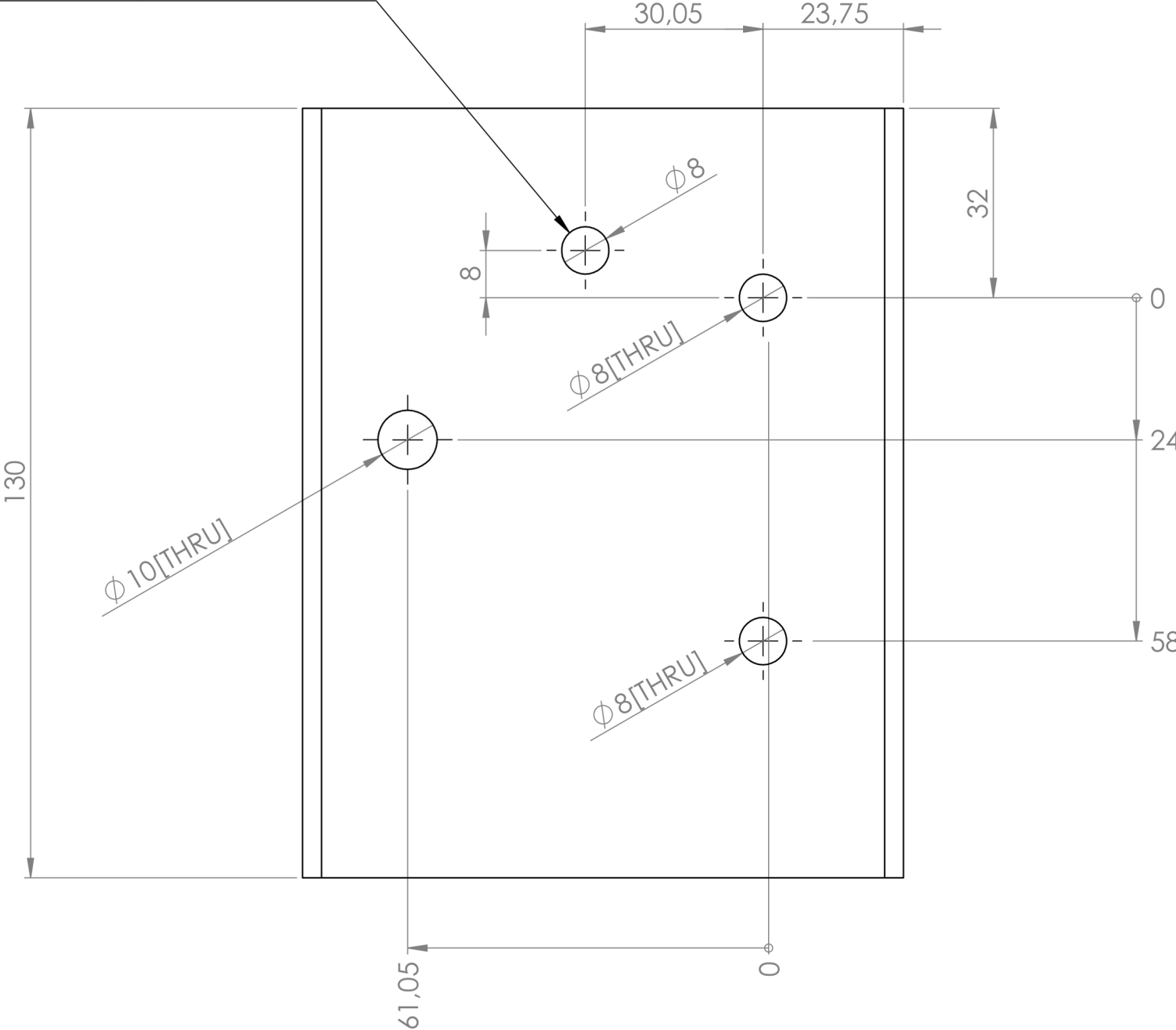

Beam Short Y2 top - Imperial

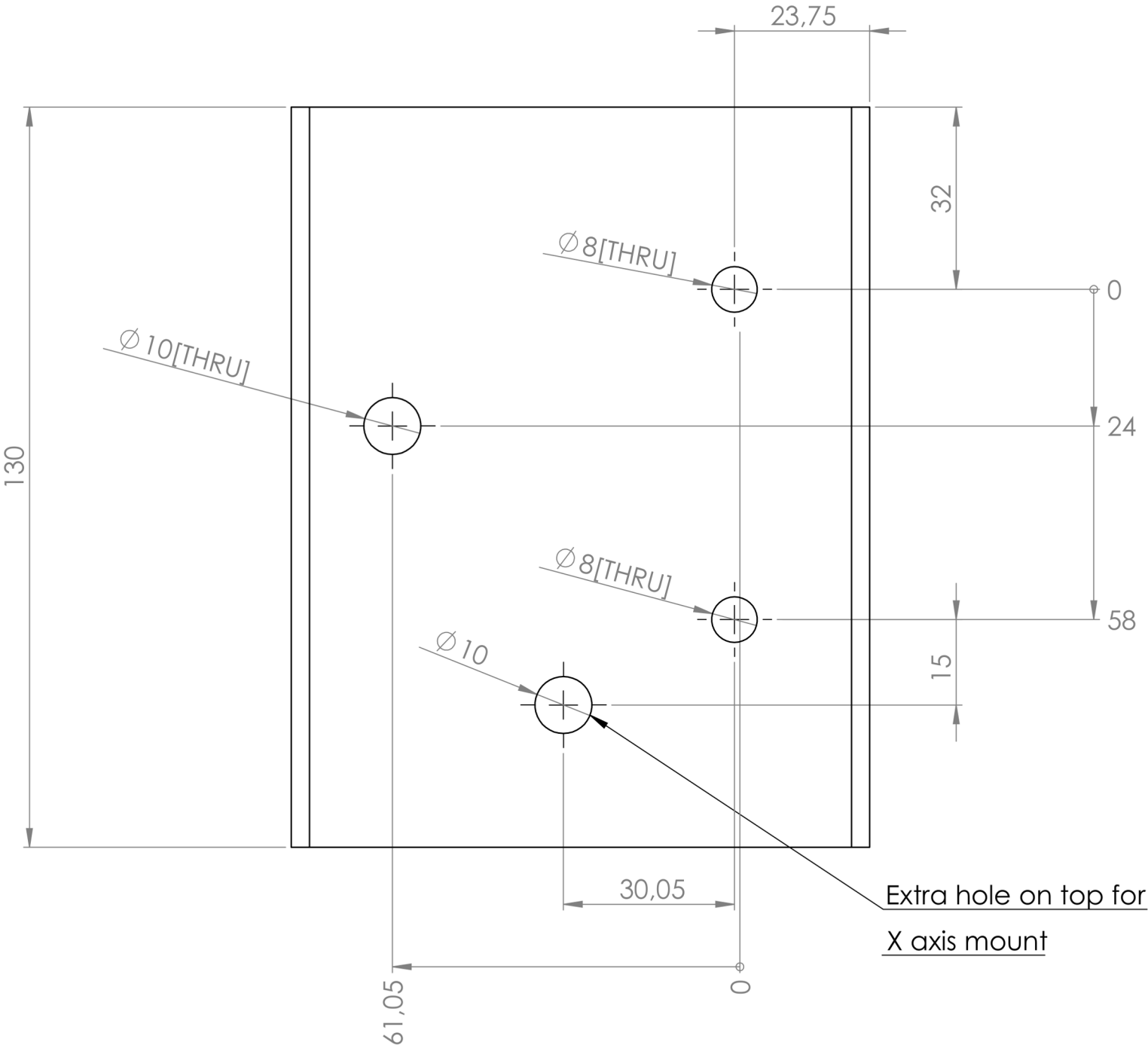

Tightener Plate

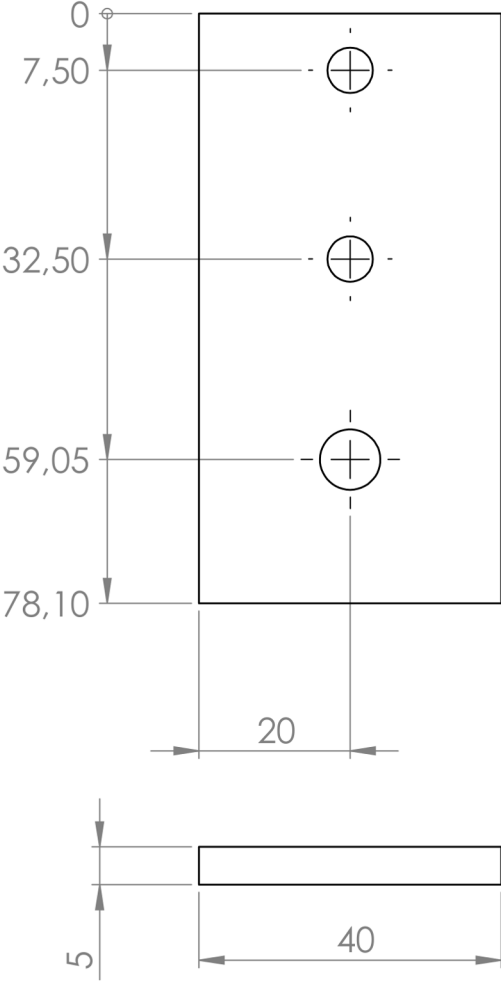

Z Plate Upper

