

PROJECT INFORMATION
 NEW HOUSE PROJECT FOR OPEN SOURCE ECOLOGY
 MULTIPLE LOCATIONS
 KANSAS CITY AND ST. JOSEPH AREA
 MARCIN JAKUBOWSKI

ISSUES & REVISIONS

#	DATE	DESCRIPTION
1	9/1/2022	STRUCTURAL REVIEW
2	9/21/2022	MARKUPS
3	9/29/2022	MARKUPS
4	10/21/2022	MARKUPS

DRAWN BY: MLR
 CHECKED BY: SBA
 ISSUED FOR:

SHEET TITLE
 SECTIONS AND CONNECTIONS

SHEET NUMBER
 S12

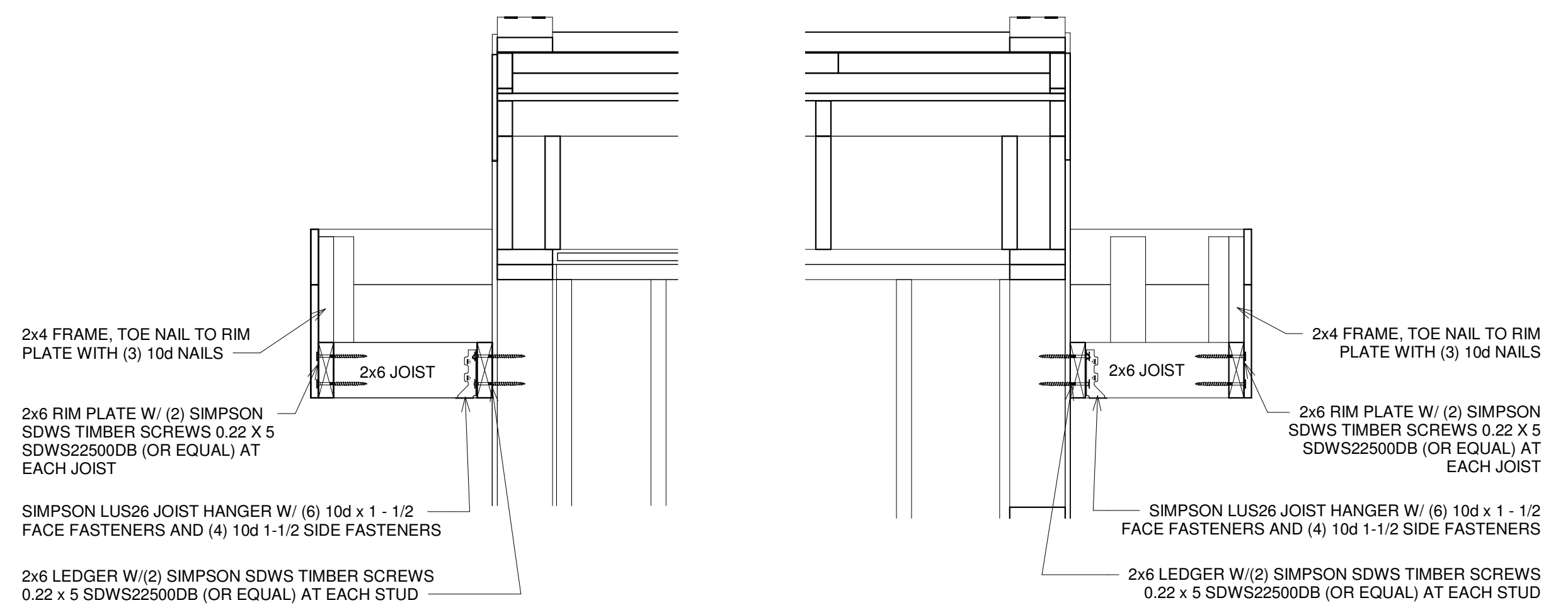

2 PARAPET LEFT
 SCALE: 1" = 1'-0"

3 PARAPET RIGHT
 SCALE: 1" = 1'-0"

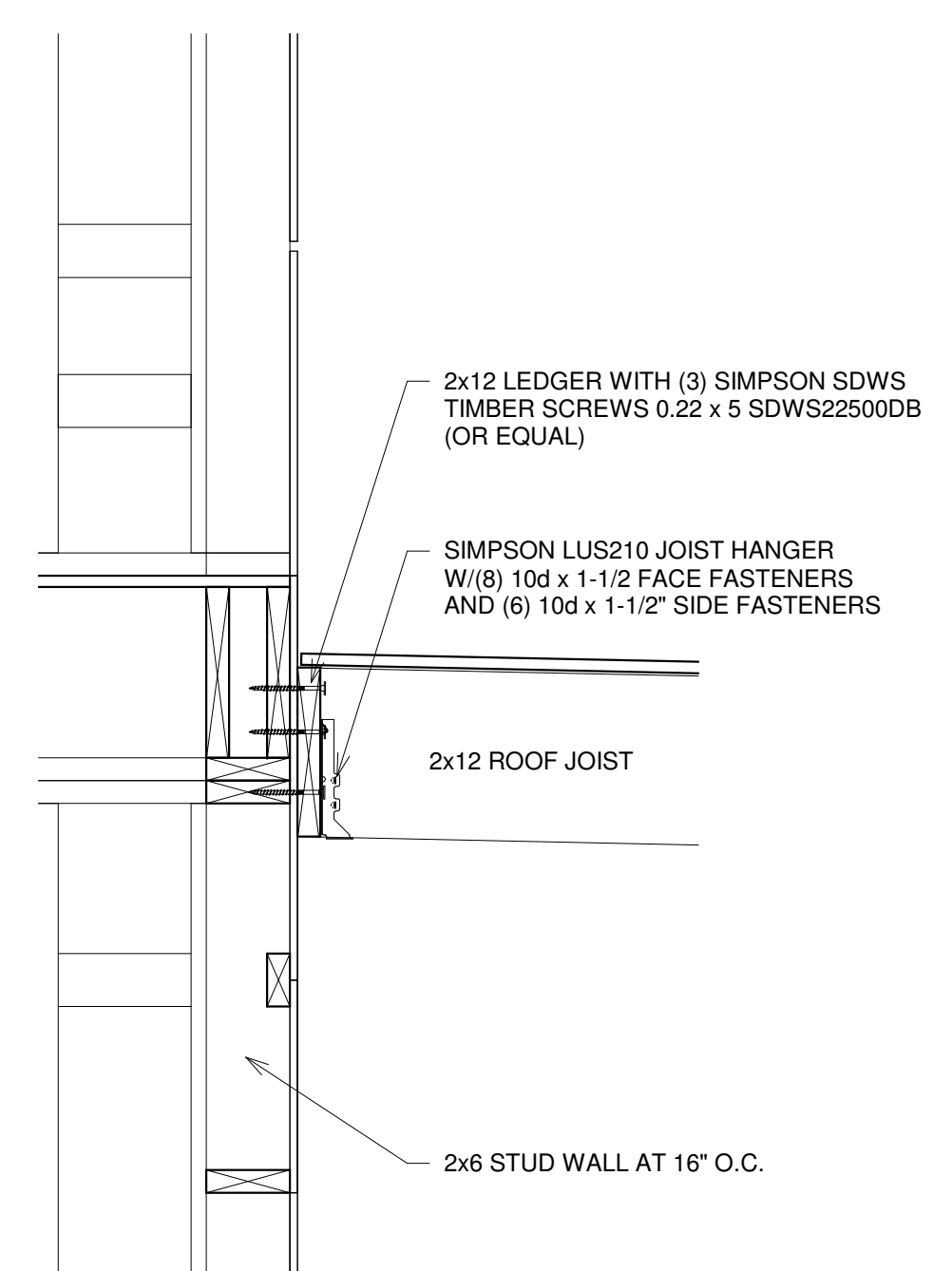

4 BALCONY FLOOR JOISTS
 SCALE: 1" = 1'-0"

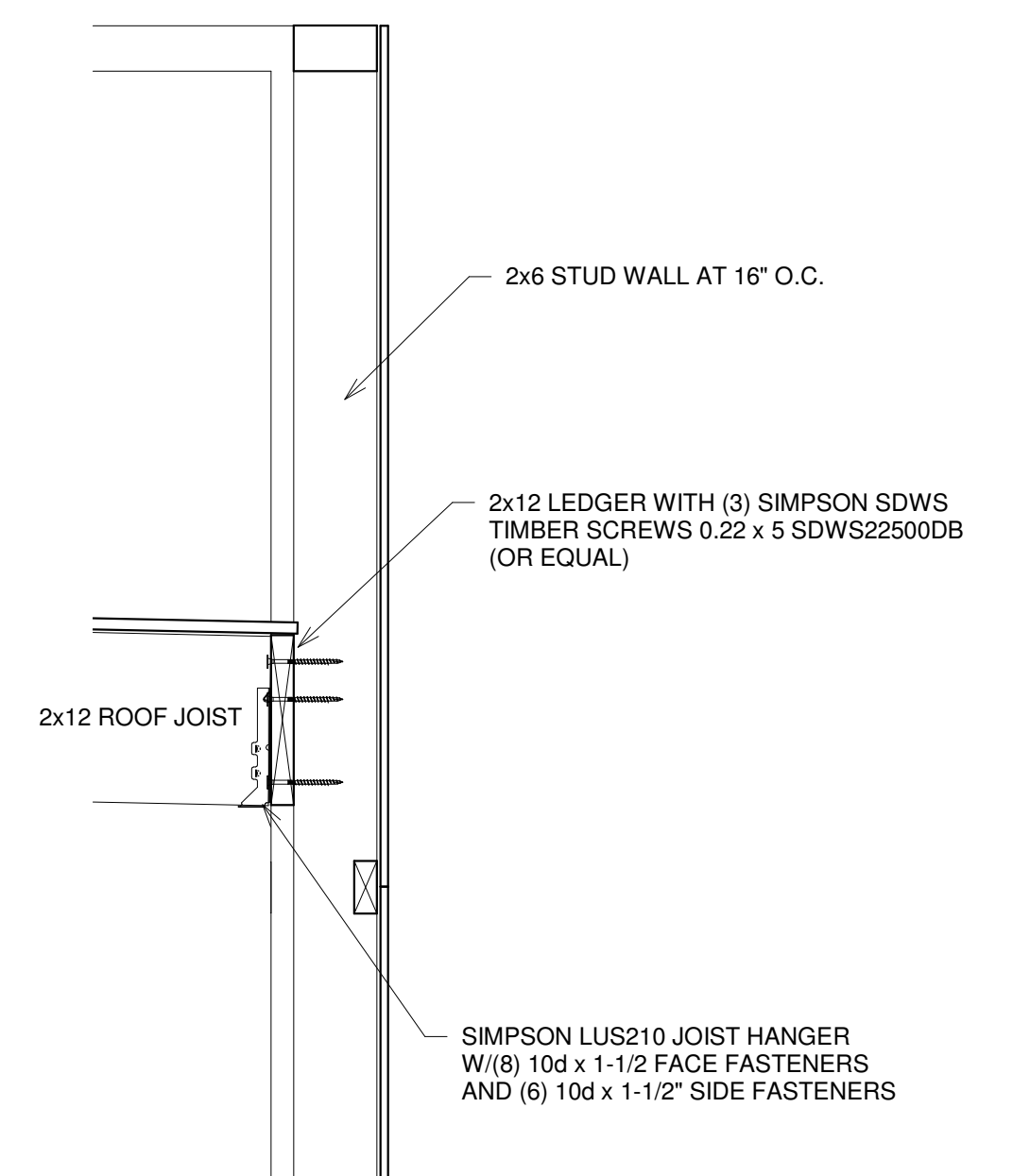

5 BALCONY FLOOR JOISTS
 SCALE: 1" = 1'-0"

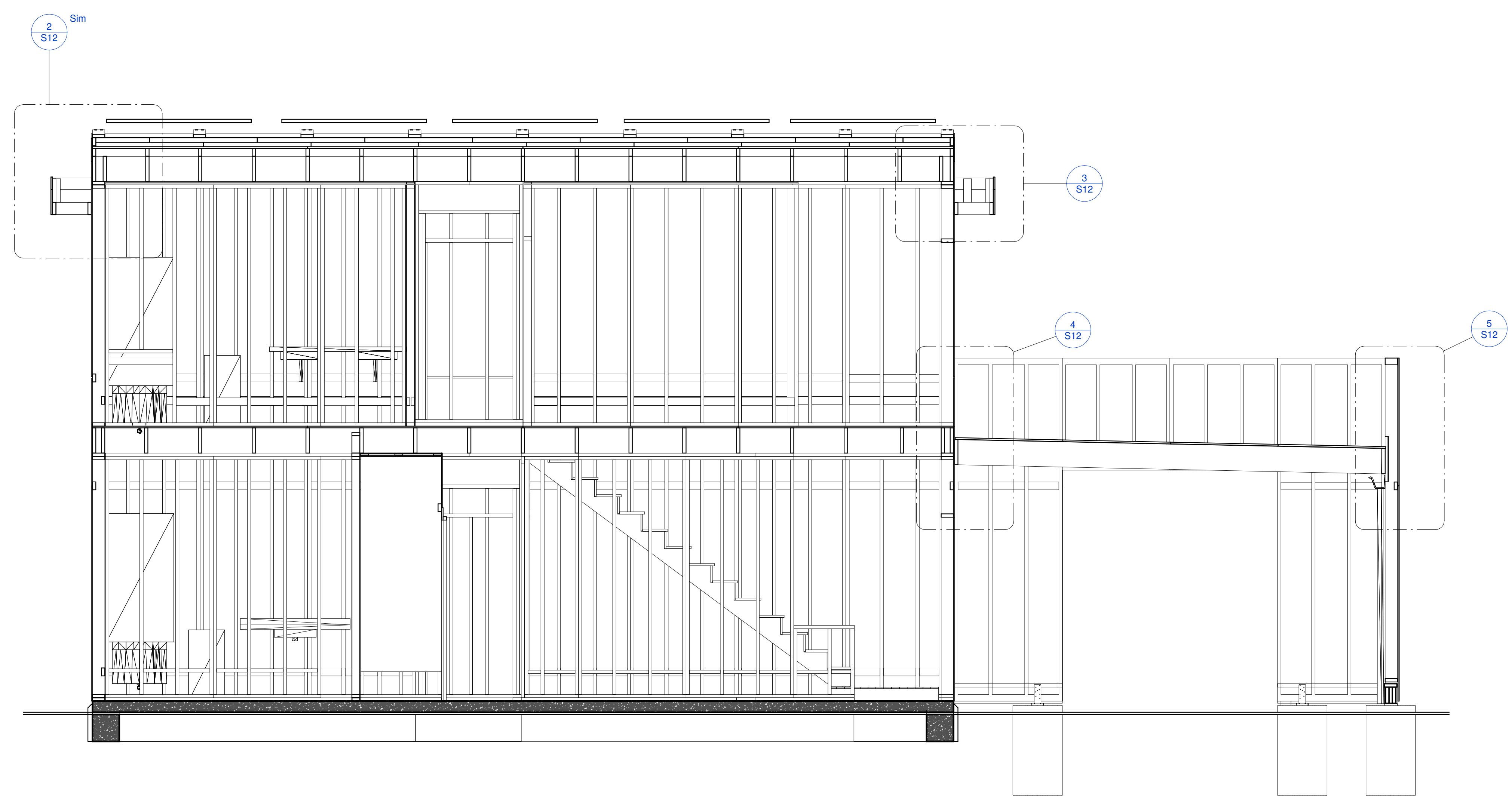

1 SECTION
 SCALE: 3/8" = 1'-0"

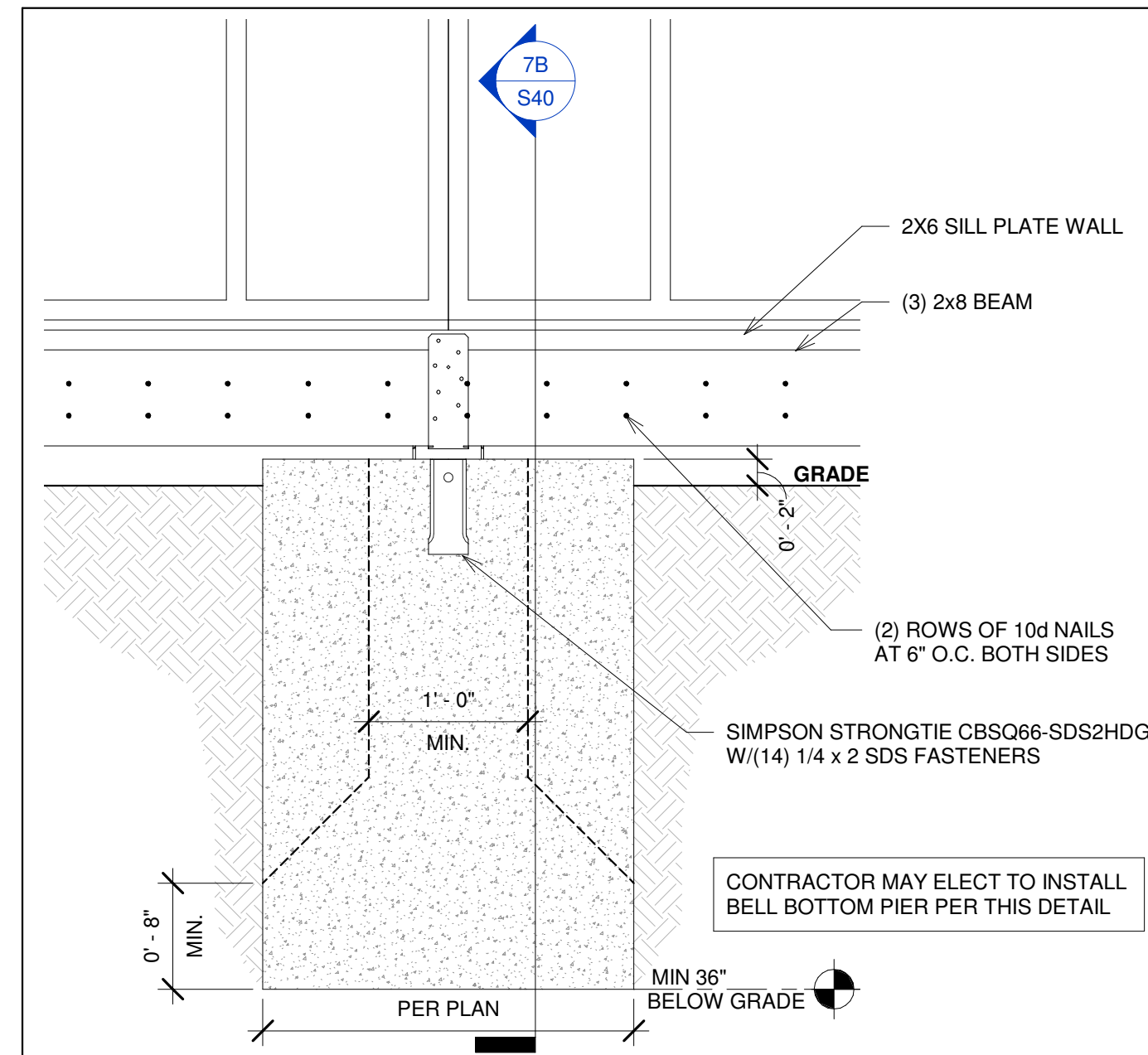

7A SECTION 7A
SCALE: 1" = 1'-0"

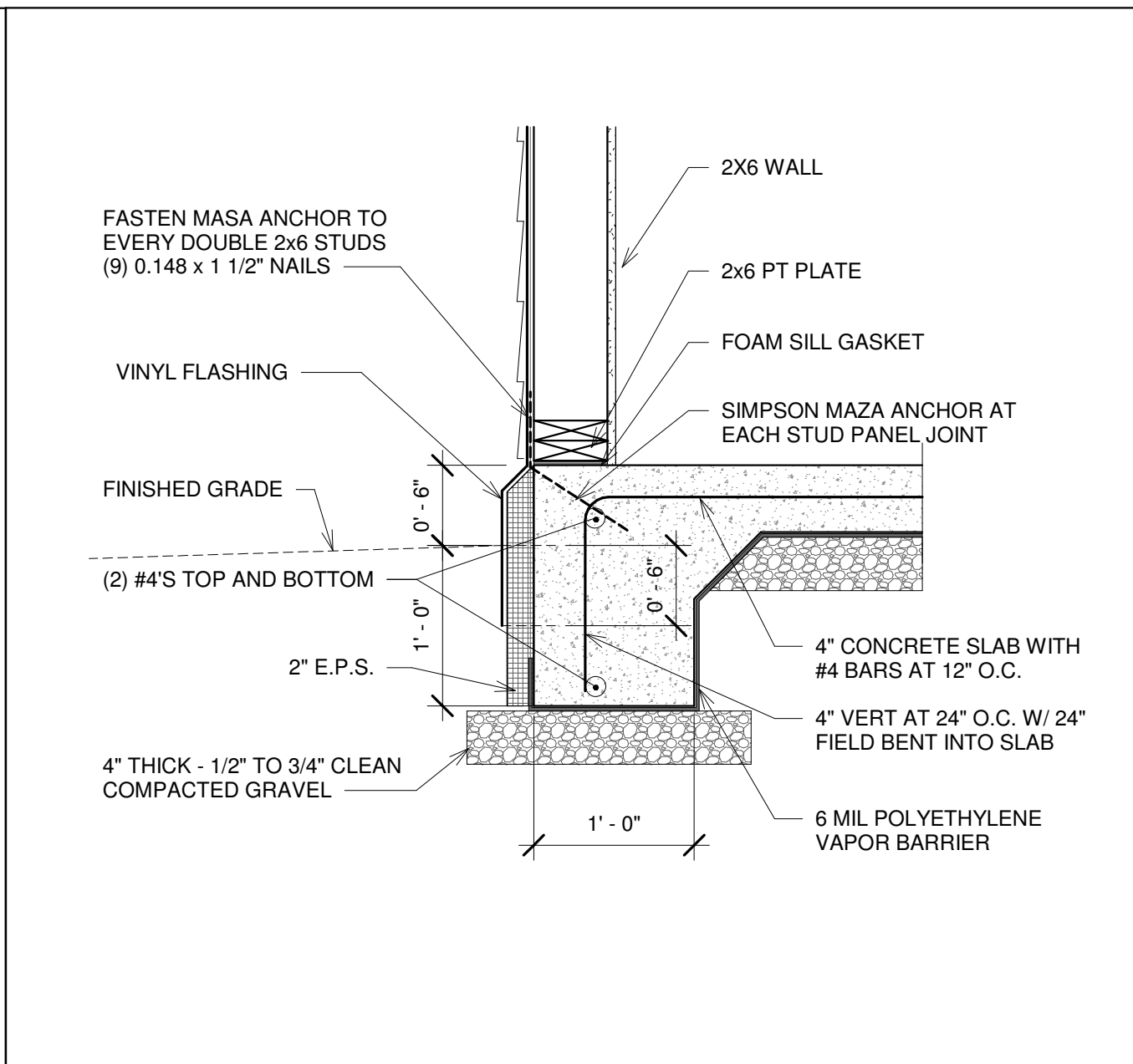

4 TYPICAL EXTERIOR FOOTING
SCALE: 1" = 1'-0"

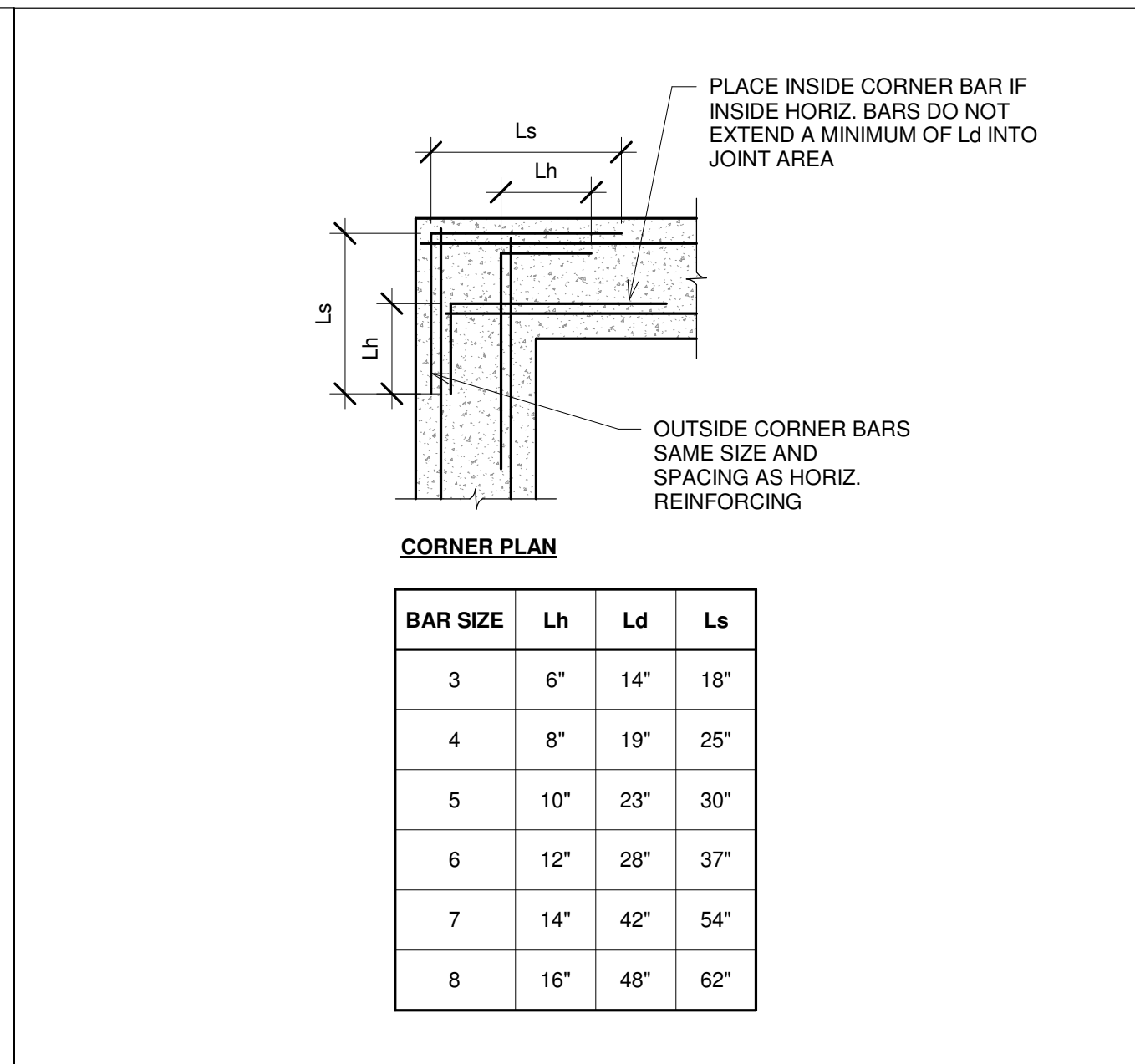

3 TYP WALL AND GRADE BEAM DETAILS
SCALE: 3/4" = 1'-0"

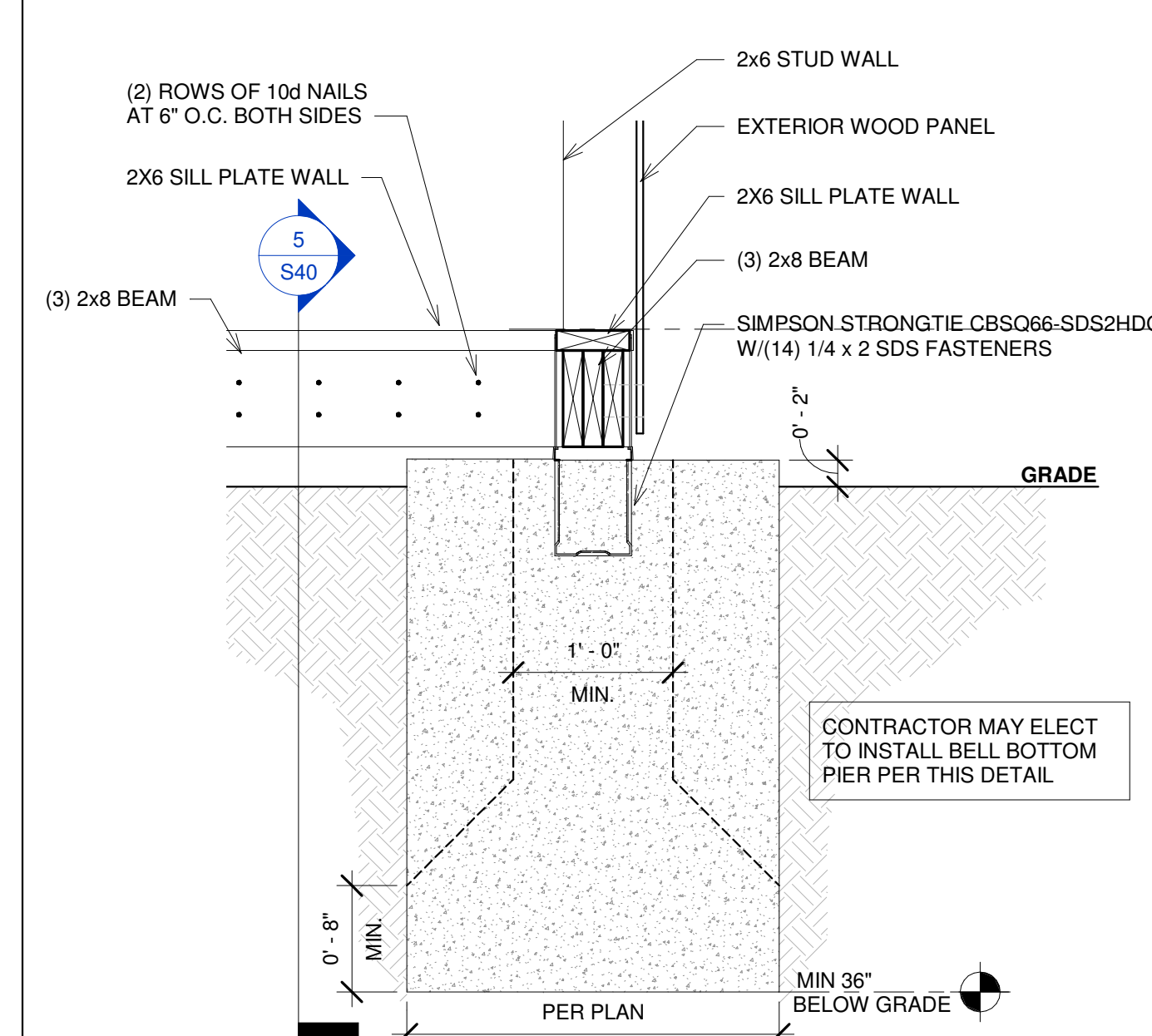

7B SECTION 7B
SCALE: 1" = 1'-0"

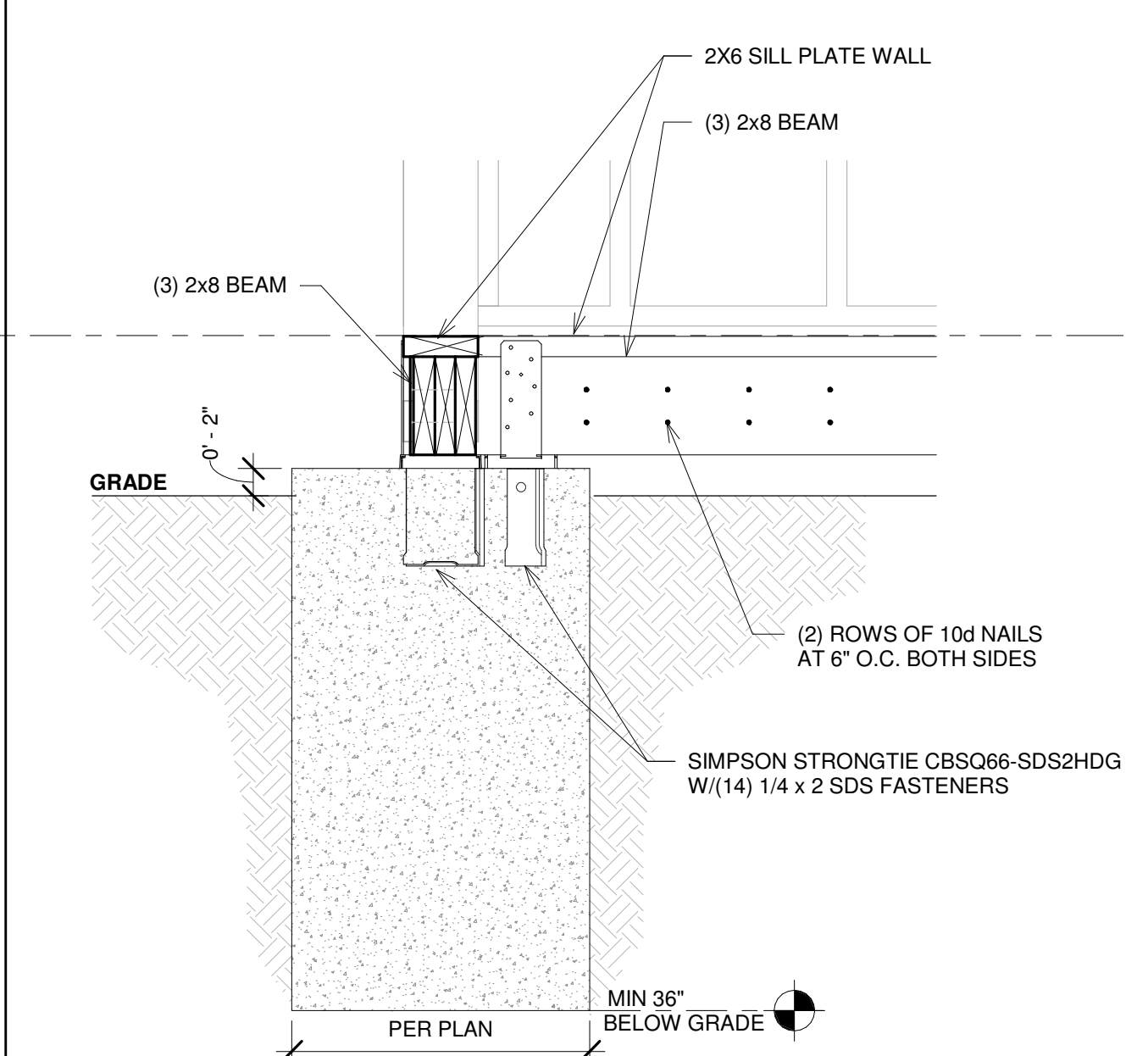

5 CORNER CARPORT PIER
SCALE: 1" = 1'-0"

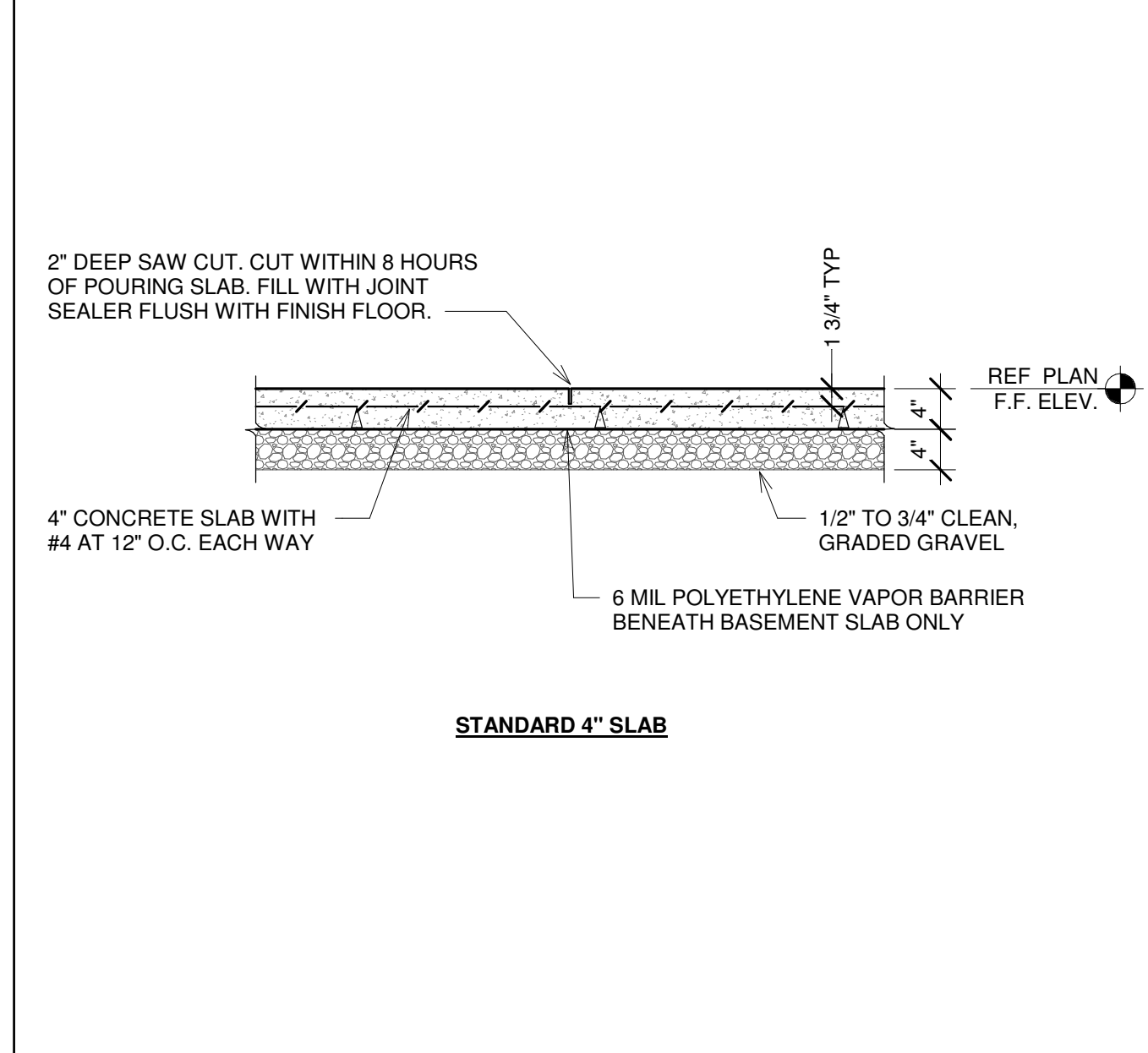

2 STANDARD SLAB DETAILS
SCALE: 3/4" = 1'-0"



6 ENTRY CARPORT PIER
SCALE: 1" = 1'-0"

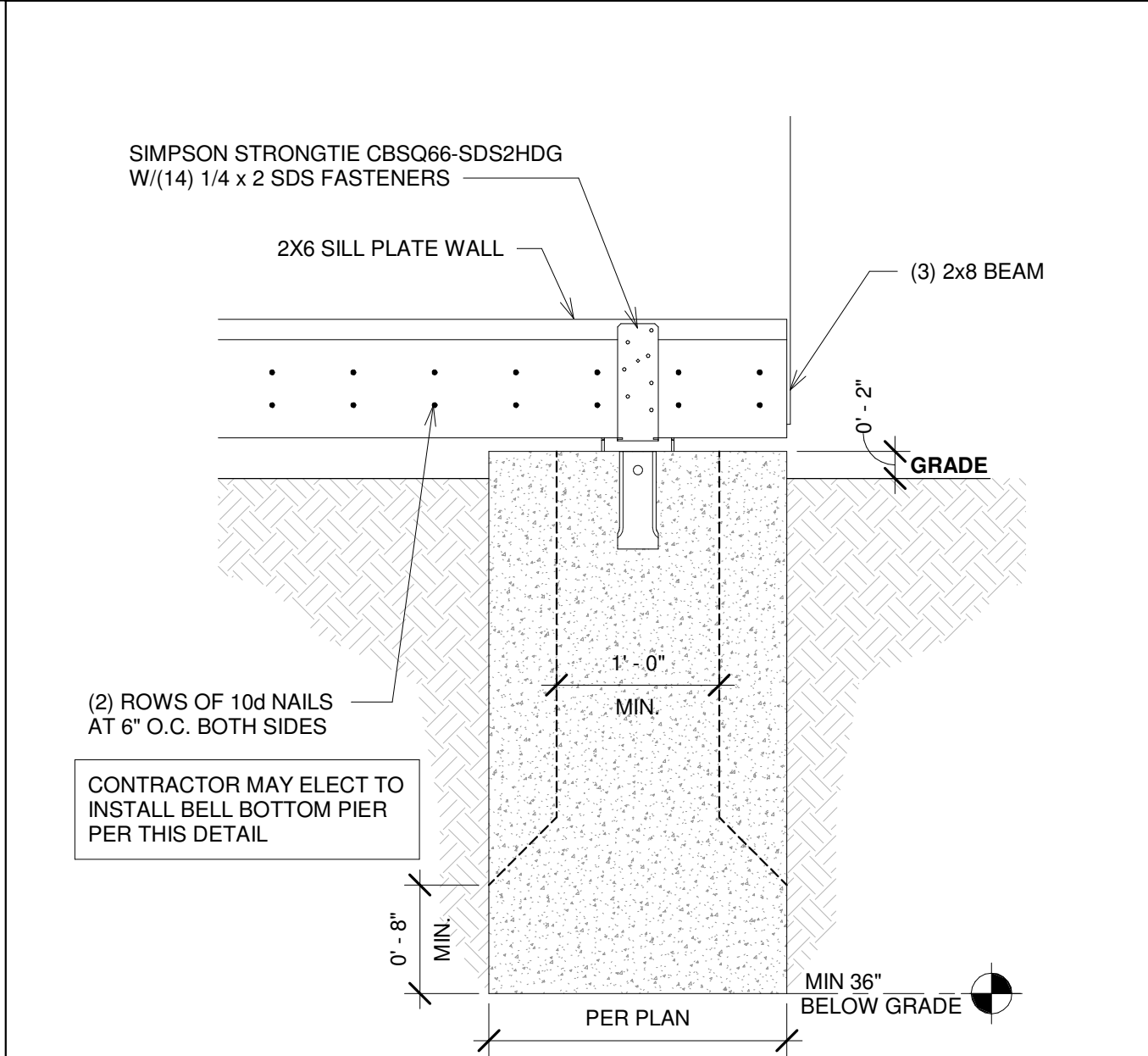

1 INTERIOR BEARING WALL
SCALE: 1" = 1'-0"

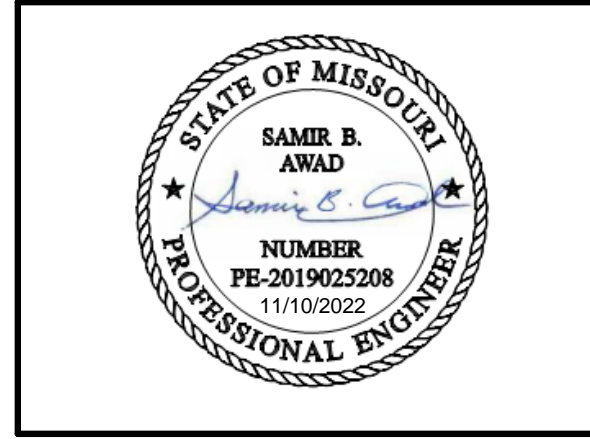

PROJECT INFORMATION
NEW HOUSE PROJECT FOR OPEN SOURCE ECOLOGY
MULTIPLE LOCATIONS
KANSAS CITY AND ST. JOSEPH AREA
MARCIN JAKUBOWSKI

ISSUES & REVISIONS

#	DATE	DESCRIPTION
1	9/1/2022	STRUCTURAL REVIEW
2	9/21/2022	MARKUPS
3	9/29/2022	MARKUPS
4	10/21/2022	MARKUPS

DRAWN BY: MLR
CHECKED BY: SBA
ISSUED FOR:

SHEET TITLE
STANDARD DETAILS

SHEET NUMBER
S40