

Development of a Functional Basis for Design

Robert B. Stone

Department of Basic Engineering,
University of Missouri-Rolla,
Rolla, MO 65409
e-mail: rstone@umr.edu

Kristin L. Wood

Department of Mechanical Engineering,
The University of Texas at Austin,
Austin, TX 78712
e-mail: wood@mail.utexas.edu

Functional models represent a form independent blueprint of a product. As with any blueprint or schematic, a consistent language or coding system is required to ensure others can read it. This paper introduces such a design language, called a functional basis, where product function is characterized in a verb-object (function-flow) format. The set of functions and flows is intended to comprehensively describe the mechanical design space. Clear definitions are provided for each function and flow. The functional basis is compared to previous functional representations and is shown to subsume these attempts as well as offer a more consistent classification scheme. Applications to the areas of product architecture development, function structure generation, and design information archival and transmittal are discussed. [S1050-0472(00)00704-2]

1 Introduction

Functional modeling is a key step in the product design process, whether original or redesign. This article reports on an inductive approach to create a common design language for use with functional models, focusing primarily on the mechanical and electromechanical domains. The common design language is termed a functional basis. It allows designers to describe a product's overall function as a set of simpler sub-functions while showing their connectivity. With such a set, designers can communicate product function in a universal language.

Several factors motivate the creation of a functional basis for mechanical design. In particular, use of the functional basis described in this article significantly contributes to the following six product design areas.

- *Product architecture development.* The desire to move the product architecture decision (i.e. modular vs. integral) earlier in the conceptual design stage necessitates basing the decision on a functional model of the product [1,2]. A modular architecture is then formed by grouping sub-functions from a functional model (such as a function structure) together to form modules. The modules identify opportunities for function sharing by components and lead to alternative layouts where concept generation techniques may be used to embody the layouts. To systematically explore product architecture possibilities across a wide variety of products, a common functional design language is needed.

- *Systematic function structure generation.* The most common criticism of functional models (particularly their graphical representation known as a function structure) is that a given product does not have a unique representation. Even within a systematic function structure generation methodology, different designers can produce differing function structures. A common set of functions and flows (the "connectivity" of the product's function) significantly reduces this occurrence. It also provides a consistent basis for developing high-level physical models, and for teaching the abstract concepts of functional modeling to engineers.

- *Archival and transmittal of design information.* Products are transient; their service lives range from days to hundreds of years, but are nevertheless transient. The design process behind a product is even more fleeting. The creation of each new product, though, adds to the collective design knowledge and needs to be recorded in a consistent manner. A functional model is an excellent way to record and communicate design information. To do so consistently, a common set of functions and flows with clear (and timeless) definitions is necessary.

- *Comparison of product functionality.* Few product designs are truly "original." Instead, they incorporate elements of other product designs that have accumulated in the corporate body of design knowledge. If functional descriptions of products, expressed in a common language, are accumulated in a repository, then that repository can be searched to find products similar in function. This offers obvious applications to benchmarking products and searching for form solutions.

- *Creativity in concept generation.* The ability to decompose a design task is fundamental to arriving at creative solutions [3]. Likewise, it is critical to represent abstract and incomplete information to make decisions early in a design process or product development. Functional models, with the addition of a functional basis, significantly aid the capacity of design teams to break problems down and make critical early decisions.

- *Product metrics, robustness, and benchmarks.* An important aspect of product development is to formulate objective measures for benchmarking and quality endeavors. Functional models can greatly enhance methods, such as Quality Function Deployment, in identifying and choosing metrics. The flows or connections of functional models provide a high-level physical model of a product's technical process. These flows, if suitably formalized, are directly measurable, reducing the guesswork and artistic nature of choosing metrics.

The scope of this article is limited to the functional modeling portion of conceptual design. Section 2 provides a glossary of common functional modeling terms. In Section 3, we review the design research leading up to the functional basis, which is presented in Section 4. A functional modeling methodology is given in Section 5 to demonstrate the placement of the functional basis within the design process. However, the functional basis for mechanical design presented in this article can be used across many methodologies. The end result is always a functional model of a product expressed in a common design language, as the example in Section 6 demonstrates.

2 Glossary of Terms

The following terms are used throughout the article in reference to various parts of the design process. They are defined here for clarity.

Product function: the general input/output relationship of a product having the purpose of performing an overall task, typically stated in verb-object form.

Sub-function: a description of part of a product's overall task (product function), stated in verb-object form. Sub-functions are decomposed from the product function and represent the more elementary tasks of the product.

Contributed by the Design Theory and Methodology Committee for publication in the JOURNAL OF MECHANICAL DESIGN. Manuscript received August 1999. Associate Technical Editor: Jonathan Cagan.

Function: a description of an operation to be performed by a device or artifact, expressed as the active verb of the sub-function.

Flow: a change in material, energy or signal with respect to time. Expressed as the object of the sub-function, a flow is the recipient of the function's operation.

Functional model: a description of a product or process in terms of the elementary functions that are required to achieve its overall function or purpose.

Function structure: a graphical form of a functional model where its overall function is represented by a collection of sub-functions connected by the flows on which they operate.

Functional basis: a design language consisting of a set of functions and a set of flows that are used to form a sub-function.

3 Background

3.1 Functional Modeling. In function-based design methodologies, functional modeling of a device is a critical step in the design process [4,5]. The systematic approach of Pahl and Beitz [4] and Hubka [6], which represents European schools of design, has spawned many variant methodologies in recent American design literature [3,7–13]. Similarly, the field of value engineering has significantly advanced our understanding of basic functions, especially with respect to economic measures [14–16]. Regardless of the variation on methodology, all functional modeling begins by formulating the overall product function. By breaking the overall function of the device into small, easily solved sub-functions, the form of the device follows from the assembly of all sub-function solutions.

The lack of a precise definition for *small, easily solved sub-functions* casts doubt on the effectiveness of prescriptive design methodologies such as those by Pahl and Beitz [4], Ullman [3], and Ulrich and Eppinger [7] among engineers in more analytical fields. For instance, within a given methodology how does one reconcile different functional models of a product generated by different designers? Typically, such differences arise from semantics or poor identification of product function. The development of a standard set of functions and flows (referred to here as a functional basis, others may call it a function taxonomy) and a systematic approach to functional modeling offers the best case to erase remaining doubt.

3.2 From Value Engineering to Functional Basis. Much of the recent work on a functional basis stems from the results of value engineering research that began in the 1940s [14–16]. Value analysis seeks to express the sub-functions of a product as an action verb-object pair and assign a fraction of a product's cost to each sub-function. Sub-function costs then direct the design effort (specifically, the goal is to reduce the cost of high value sub-functions). However, there is no standard list of action verbs and objects. Recognizing that a common vocabulary for design was necessary to accurately communicate helicopter failure information, Collins et al. [17] develop a list of 105 unique mechanical functions. Here, the mechanical functions are limited to helicopter systems and do not utilize any classification scheme.

As systematic, function-based design methodologies gained influence, the development of function taxonomies continued. Now, though, the development is based on the related needs for a clear stopping point in the functional modeling process and, hence, a consistent level of functional detail. Pahl and Beitz [4] list five generally valid functions and three types of flows, but they are at a very high level of abstraction. Hundal [18] formulates six function classes complete with more specific functions in each class, though does not claim to have an exhaustive list of mechanical design functions. Another approach uses the 20 subsystem representations from living systems theory to represent mechanical design functions [19]. Malmqvist et al. [20] compare the Soviet Union era design methodology known as the Theory of Inventive Problem Solving (TIPS) with the Pahl and Beitz methodology. TIPS uses a set of 30 functional descriptions to describe all me-

chanical design functions [21]. Malmqvist et al. note that the detailed vocabulary of TIPS would benefit from a more carefully structured class hierarchy using the Pahl and Beitz functions at the highest level. Kirschman and Fadel [22] propose four basic mechanical functions groups, but vary from the standard verb-object sub-function description popular with most methodologies. However, this work appears to be the first attempt at creating a common vocabulary of design that leads to common functional models of products.

Building on the above work, the concept of a functional basis is described in this paper, significantly extending our previous research [13,23,24]. A functional basis is a standard set of functions and flows capable of describing the mechanical design space (for our focus). Our work expands the set of functions and groups them into eight classes. Also, for the first time, a definition for each function is given. This initial functional basis subsumes all other classification schemes discussed above along with the 30 basic sub-functions found in TIPS. It is from this point that the functional basis in this article picks up. Accepting the functions of Little, we add a standard list of flows with definitions in Section 4.

3.3 Design Knowledge Archival. In addition to conceptual design work, functional models represent a means of archiving and communicating design knowledge. Augmented with other product specific data, such as a component to function map, performance specifications and/or customer needs, a functional model represents a concise body of design knowledge. Altshuler [21] recognized that patents provided a valuable store of design knowledge while developing TIPS, but are not easy to search or categorize. Currently, product databases are being developed that facilitate easier search and retrieval of product design knowledge, all based on a standard set of functions and flows [25–27].

4 An Inductive Functional Basis

The functional basis is a tool for use in generating a functional model in product design. Many different design methodologies, which include a functional decomposition component, are mentioned briefly in Section 3. Purposely, no detailed description of any one method is given prior to the introduction of the functional basis. By doing so, we hope to emphasize the broad-based applicability of the functional basis. Regardless of the specific technique used to create a functional model (such as a hierarchical decomposition or task listing approach), the basis identifies when an overall function is decomposed to a *small, easily solvable* sub-function and, thus, provides a common level of detail. Implied in this is the representation of product function in a common language, eliminating semantic confusion.

The only requirement of the functional basis is that functions (both overall and sub-) must be expressed as a verb-object pair. The basis functions fill the verb spot and the basis flows provide the object. Next, the functional basis flows and functions are presented. In each case, the logic behind the classification scheme and the usage rules are given. Finally, several previous function taxonomies are compared to and shown to be subsumed by the functional basis.

4.1 Flows. An essential component of any functional modeling approach is the representation of the quantities that are input and output by functions. These quantities (or entities) are known as flows. This research has developed formal representations of flows through a careful study of many fields within the physical and natural sciences. Analogies have also been adopted from other modeling approaches, such as dynamics and bond graphs. The results of these studies have then been applied to hundreds of products as part of this research. Reverse engineering exercises, product development, and industrial applications have served as the vehicles for the product applications.

Energy, matter and information are considered basic concepts in any design problem [4]. It is the flow of these three concepts that concerns designers. Matter is better represented as material.

Table 1 Flow classes, basic and sub-basic flows and complements [28]. Complements with gray backgrounds may be treated as stand alone objects in the verb-object pair.

Class	Basic	Sub-basic	Complements		
Material	Human		Hand, foot, head, etc.		
	Gas				
	Liquid				
	Solid				
Signal	Status	Auditory	Tone, Verbal		
		Olfactory			
		Tactile	Temperature, Pressure, Roughness		
		Taste			
	Visual	Position, Displacement			
Control					
Bond graph based complement					
Class	Basic	Sub-basic	Effort analogy	Flow analogy	
Energy	Human		Force	Motion	
	Acoustic		Pressure	Particle velocity	
	Biological		Pressure	Volumetric flow	
	Chemical		Affinity	Reaction rate	
	Electrical		Electromotive force	Current	
	Electromagnetic	Optical		Intensity	Velocity
		Solar		Intensity	Velocity
	Hydraulic		Pressure	Volumetric flow	
	Magnetic		Magnetomotive force	Magnetic flux rate	
	Mechanical	Rotational		Torque	Angular velocity
		Translational		Force	Linear velocity
		Vibrational		Amplitude	Frequency
	Pneumatic		Pressure	Mass flow	
	Radioactive		Intensity	Decay rate	
	Thermal		Temperature	Heat flow	
Usage & Degree of Specification					
Class only Least Specific▼	Basic or Sub-basic + Class				
	More Specific▼				
	Basic or Sub-basic + Complement				
	Most Specific▼				
Overall increasing degree of specification ➡					

Information is more concretely expressed as a signal. Signals, in actuality, are either flows of material or energy, but receive a special classification because their function is to carry information.

All design problems deal with these three basic flows, but it seldom advances the design solution to deal with flows at this highest level. We specify these flows more accurately to form the vocabulary of standardized flows of the functional basis. The functional basis flows are shown in Table 1.

General Functional Basis Flow Usage. The representation of flows carries critical physical information about a product's technical system. It is possible to represent flow at such a high-level of abstraction that little meaning can be derived. Likewise, a natural language, such as English, provides too vast a range of possible descriptors, so that ambiguity and redundancies may arise. We address these issues through the development of flow classes, in addition to refinements within each class.

Within each flow class, flows are broken into basic and sub-basic flows. In practice, a basic flow is described by a basic descriptor+its class. For example, *human energy* is a basic flow. Sub-basic flows are described by a sub-basic descriptor+its class. An example is the flow *auditory signal*. Basic and sub-basic flows may be further specified by adding a complement. Here the flow description is formed by a basic (or sub-basic) descriptor+a complement. A more specific description of the *human energy* used by a product such as a power screwdriver is *human force*. A few special cases exist where complements stand alone in describing a flow. Stand alone complements are denoted by a gray background. Taking an engine, for example, we may be interested in the *torque* produced by the engine (instead of the more cumbersome *rotational torque*).

The degree of specification depends on the type of design and customer needs (and process choices resulting from customer needs). Using a more general flow description produces a generic function structure and, thus, a wider range of concept variants. However, if customer needs dictate concreteness in flows, then an increasingly specific complement is more valuable. Another use

of the flow set (and function set in the following sub-section) is to compare different devices on a functional level. In this case, the flows (and functions) should be expressed in their basic categorization to capture similarities between devices. The possible levels of specification are depicted schematically in the bottom *Usage and Degree of Specification* portion of Table 1.

An Inclusive Case: Human Flow. Considering the material and energy classes, both have basic flows of "human." The importance in human crossing of device boundaries merits this special inclusion. Often the requirement of human interaction is known at an early stage of design. By its specification, it will guide the design to appropriate solutions faster.

Signal Flow Particulars. Signals, while in actuality either material or energy, receive their own class because their role is to carry information. Here, signals are treated as two basic flows used for conveying status or control information.

Energy Flow Particulars. Energy flow complements are divided into effort and flow analogies based on energy- (or power-) based modeling methods, such as contained in the bond graph literature [29]. These complements are shown in the final two columns of Table 1. Only one of the complements is used to further specify a basic or sub-basic energy flow. The energy flow complements are labeled as effort and flow *analogies*. Not every basic energy flow in Table 1 will have power as the product of its effort and flow analogies, as would a true power-based effort and flow product. The effort and flow analogies' product is scalable to power, though. The effort and flow analogies were created because they provide a consistent categorization of flows, eliminating confusion when increasing specification is needed. They also identify variables that are important in future analysis. For instance, in a hand held power screwdriver, is the relevant flow out of the motor *angular velocity* or *torque*? Of course both exist, but *torque* is the correct choice to describe the situation because the effort is the more important output of the power screwdriver, based on the primary customer need of inserting screws easily. When mathematical models of the device are created, a formulation for the output torque will be required as expressed by the function structure.

Definitions of Functional Basis Flows. Not only is a consistent division of basic flows necessary, but also a clear definition for all flows. Flow definitions are given in Appendix A. For materials, basic physics provides suitable definitions. The energy class is specified further by a bond graph approach of effort and flows [29–32]. Signals are defined from a human factors standpoint [33].

4.2 Functions. As with flows, functions are formalized through a study of past methods, in addition to the patents and other literature. Through these studies, the functions have been used to represent hundreds of products, both redesigns and original developments.

The function classes used in the functional basis are given in Table 2. The first column lists the eight function classes. These classes are extended to include basic functions in the second column. The third column lists functions that are only valid when used with an appropriate flow. For example, the function *transmit* is limited to use with the flow classes energy and signal and the function *transport* is used with the flow class material. The last column lists synonyms for the basic functions. These are terms that commonly appear in non-basis function structures and aid in transforming a function structure. Definitions and examples for each of the functional basis functions are presented in Appendix B.

Alternative Uses of the Verb-Object Format. A functional basis function always occupies the verb position of the standard verb-object sub-function description. However, the verb-object format may be applied more liberally for some basic functions,

Table 2 Function classes, basic functions and synonyms [23,24]. Repeated synonyms are italicized.

Class	Basic	Flow restricted	Synonyms	
Branch	Separate		Switch, Divide, Release, Detach, Disconnect, Disassemble, Subtract	
		Remove	Cut, Polish, Sand, Drill, Lathe	
	Refine		Purify, Strain, Filter, Percolate, Clear	
Channel	Distribute		Diverge, Scatter, Disperse, Diffuse, Empty Absorb, Dampen, Dispel, Resist, Dissipate	
	Import		Input, Receive, <i>Allow</i> , Form Entrance, <i>Capture</i>	
Channel	Export		Discharge, Eject, Dispose, Remove	
	Transfer			
		Transport		Lift, Move
	Transmit		Conduct, Convey	
	Guide			Direct, Straighten, Steer
		Translate		
Rotate			Turn, Spin	
Connect	Couple		Constrain, Unlock	
	Mix		Join, Assemble, <i>Attach</i>	
Control Magnitude	Actuate		Combine, Blend, Add, Pack, Coalesce	
	Regulate		Start, Initiate	
	Change		Control, <i>Allow</i> , <i>Prevent</i> , Enable/Disable, Limit, Interrupt, Valve	
		Form		Increase, Decrease, Amplify, Reduce, Magnify, Normalize, Multiply, Scale, Rectify, Adjust
Convert	Convert		Compact, Crush, Shape, Compress, Pierce	
	Condition			
Provision	Store		Transform, Liquefy, Solidify, Evaporate, Condense, Integrate, Differentiate, Process	
	Supply		Contain, Collect, Reserve, <i>Capture</i>	
	Extract		Fill, Provide, Replenish, Expose	
Signal	Sense		Perceive, Recognize, Discern, Check, Locate	
	Indicate		Mark	
	Display			
	Measure		Calculate	
Support	Stop		Insulate, Protect, <i>Prevent</i> , Shield, Inhibit	
	Stabilize		Steady	
	Secure		<i>Attach</i> , Mount, Lock, Fasten, Hold	
	Position		Orient, Align, Locate	

such as *allow DOF*, *couple*, *mix* and *convert*. Such extensions provide for more expressiveness in the representation, as indicated by these four functions as outlined below (followed by simple examples).

allow DOF: *allow flow DOF* (Ex.: *allow rotational energy DOF*)

convert: *convert flow1 to flow2* (Ex.: *convert electrical energy to mechanical energy*)

mix(couple): *mix(couple) flow1 and flow2* (Ex.: *mix solid and liquid*)

4.3 Comparison of Functional Basis with Other Taxonomies. Three function and flow taxonomies are compared to the functional basis in Fig. 1. Pahl and Beitz suggest high level functions and flows. The set of functions and flows become more detailed as Hundal refines them. The number of function classes increases from five to six and 38 basic functions are developed. The functional basis expands the number of function classes to eight, but reduces the total number of basic functions to 32. Though Hundal lists more basic functions, some are redundant and therefore removed in the functional basis. For example, Hundal's convert class uses eight basic functions to do what one does in the functional basis. Consider a kitchen blender. In Hundal's taxonomy, one of its subfunctions might be *liquefy material*. The functional basis describes the sub-function as *convert solid to liquid*. Now, consider an ice maker unit of a refrigerator. Hundal's taxonomy would list the freezing sub-function as *solidify material*. The functional basis again uses the convert sub-function to describe the action as *convert liquid to solid*. The lines of Fig. 1 show how Hundal's taxonomy subsumes Pahl and Beitz's high level set and, subsequently, how the functional basis subsumes Hundal's taxonomy.

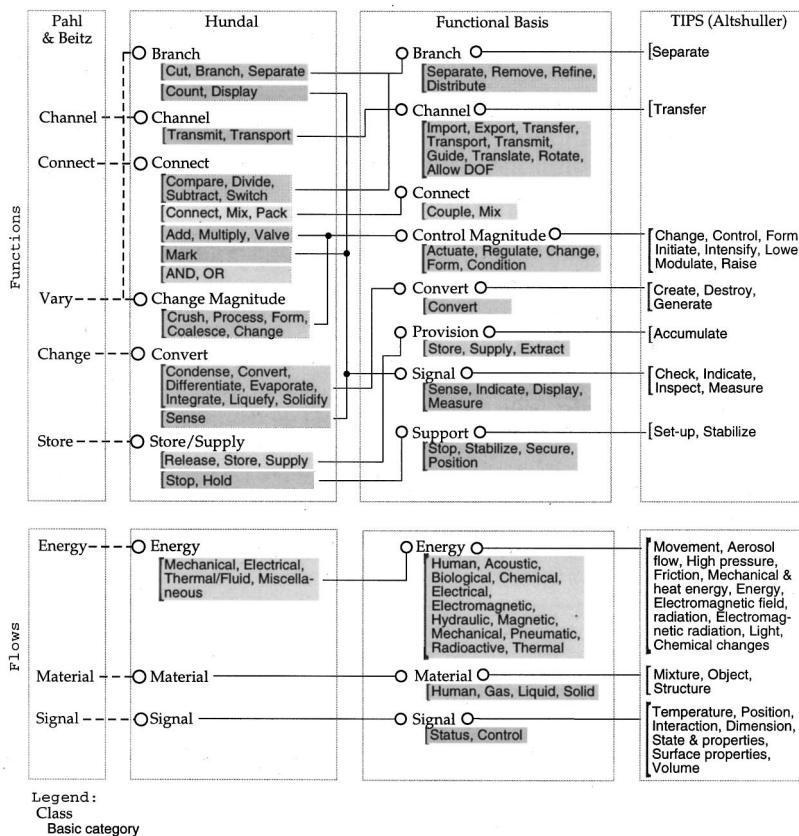

Fig. 1 Comparison of earlier function taxonomies with the functional basis. TIPS 30 function descriptions are also represented as functions and flows and shown to be subsumed by the functional basis. The taxonomies to the left of the functional basis column have evolved from function-based design methodologies while the TIPS was an independent development from the Soviet Union.

The functional descriptions of TIPS are also subsumed by the functional basis. The 30 functional descriptions are broken into function and flow sets and then grouped according to functional basis classes (shown in Fig. 1). Note the large number of TIPS functions associated with the control magnitude class. This is consistent with the Altshuller's casting of design problems as a system conflict to be resolved or controlled.

In short, the functional basis subsumes previous taxonomies and offers a more complete and consistent set of functions and flows that is nonredundant. Coupled with the clear definitions, a deficiency of other taxonomies noted by previous researchers (see Sec. 3.2), the functional basis offers the potential of a universal design language.

5 Functional Model Derivation Incorporating the Functional Basis

This section details a specific methodology to derive a functional model using the functional basis of Section 4. It consists of three tasks and is presented with an example to clarify the concepts.

5.1 Task 1: Generate Black Box Model. The first task of the functional model derivation is to create a Black Box model, a graphical representation of product function with input/output flows. The overall function of the product is expressed in verb-object form. The input/output flows are most easily established after the development of a set of customer needs for the product. Systematic and repeatable techniques for gathering customer needs are well described in literature [3,7,13,34]. This task relates the customer needs to the functional model. Each customer need

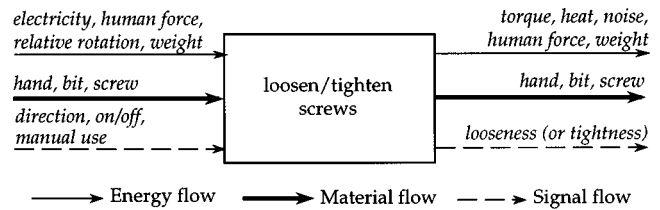

Fig. 2 A Black Box model for a power screwdriver

identifies one or more input or output flows for the product. These flows, in turn, directly address the specific customer need.

In general, customer needs only identify input or output flows, not flows internal to the product. The level of detail at which input/output flows are identified at this point depends upon the type of design undertaken. In redesign, the flows are typically well defined and benefit from the use of precise descriptions. However, in a conceptual design problem, flows may be listed more generally (even as *material*, *energy* and *signal*) and refined as the design concepts develop.

An example Black Box model for a consumer power screwdriver is shown in Fig. 2. Note that the system boundary chosen treats the bit as an input flow. This choice was based on the customer need of interchangeable bits. Flows are represented rather specifically since the power screwdriver is an existing product.

5.2 Task 2: Create Function Chains for Each Input Flow. For each input flow, Task 2 develops a chain of sub-functions that

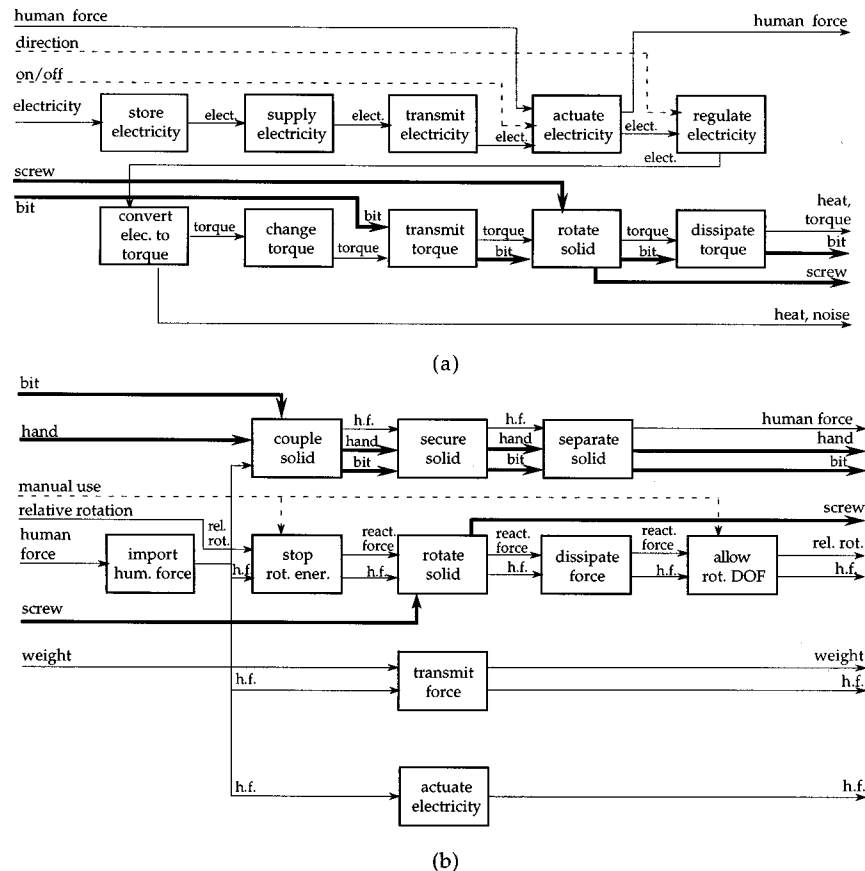

Fig. 3 Examples of two function chains for a power screwdriver. (a) A sequential function chain for the flow of *electricity* and *torque*. (b) A parallel function chain for the flow of *human force*.

operate on the flow. Here, the designer must ‘become the flow.’ Think of each operation on the flow from entrance until exit of the product (or transformation to another flow) and express it as a sub-function in verb-object form. If a flow is transformed to another type, then follow the operations on the transformed flow until it exits the product. Examples of two function chains for the power screwdriver are shown in Fig. 3. In Fig. 3(a), a function chain for the flow *electricity* is developed. By ‘becoming the flow,’ the designer realizes that five sub-functions operate on *electricity* before it is converted to *torque*. Four additional sub-functions then act on *torque* before it exits the product boundary.

Subtask 2A: Express Sub-Functions in a Common Functional Basis. The function chains (and the subsequent functional model) are expressed in the standard vocabulary of the functional basis. Using the definitions provided in Appendices A and B, functions and flows (from Tables 1 & 2) are combined in verb-object form to describe a sub-function. Expressing a functional model in functional basis form provides the general benefit of repeatable function structures among different designers. Furthermore it offers a standard level of detail for functional models, a means of verifying the consistency and correctness of the physical system, and an important stepping stone for education.

Subtask 2B: Order Function Chains With Respect to Time. Next, the functional model is ordered with respect to time. Traditional decomposition techniques, like the Pahl & Beitz method, trace flows through sub-functions without regard for the dependence of sub-functions on a specific order. Ulrich & Eppinger [7], though, note that task dependencies for product development processes are either parallel, sequential or coupled with respect to time. Here we extend the concept of parallel and sequential dependencies to sub-functions and flows of a functional model. In each case, the dependencies are defined with respect to a given flow.

In *sequential function chains*, the sub-functions must be performed in a specific order to generate the desired result. A flow common to all these functions is termed a *sequential flow*. For the power screwdriver, the flow *electricity* produces a sequential function chain in Fig. 3(a). Here, five sub-functions must operate on the flow of electricity in a specific order to obtain the desired result of usable electrical energy.

Parallel function chains consist of sets of *sequential function chains* sharing one or more common flows. Graphically, they are represented by a flow which branches in a functional model. Collectively, the chains are called *parallel* because they all depend on a common sub-function and flow, but are independent of each other. Independence means that any one of the chains of the parallel function chain set does not require input from any other chain within the set. Physically, the parallel function chains represent different components of a device that may operate all at once or individually. Figure 3(b) shows an example of a parallel function chain for the power screwdriver. In it, the flow *human force* branches to form parallel chains of sub-functions. The four chains operate independent of each other (the first is concerned with the insertion and removal of the screw bit, the second deals with the manual use of the screwdriver, the third transmits the weight of the product and the fourth actuates the device).

5.3 Task 3: Aggregate Function Chains Into a Functional Model. The final task of functional model derivation is to aggregate all of the function chains from Task 2 into a single model. It may be necessary to connect the distinct chains together. This action may require the addition of new sub-functions or their combination, defining the interfaces of modules within the representation. The aggregated functional model for the previously discussed power screwdriver is shown in Fig. 4. Note that both function chains from Fig. 3 are present and that links between flows of *bit* and *screw* are added. Also, the actuate electricity leg of the *human force* parallel chain is combined with the *electricity* sequential chain.

The result of the derivation is a functional model of a product expressed in the functional basis. With such a functional model, functions may be directly related to customer needs, products and their functional representations may be directly compared, product families may be identified, product functions may be prioritized, and direct component analogies may be generated within and outside product classes.

6 Example

As an example application of the functional basis, two functional models of a hot air popcorn popper are compared; one is generated by a design team without any knowledge of the func-

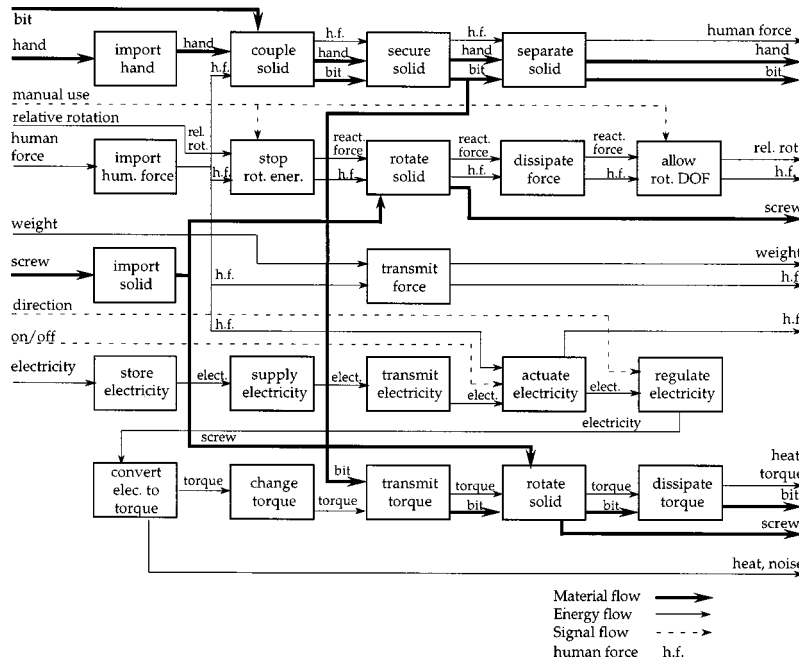

Fig. 4 The functional model for a power screwdriver

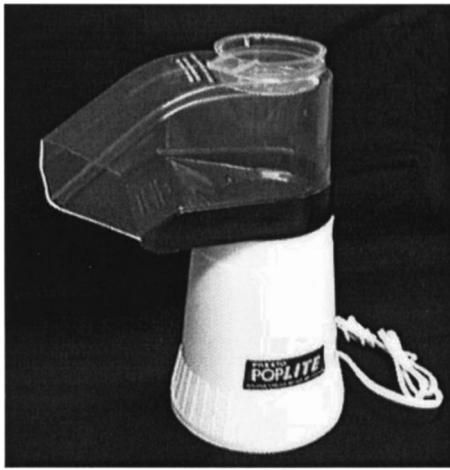

Fig. 5 The hot air popcorn popper discussed in this example

tional basis and the second is generated by the authors with the standard vocabulary of the functional basis. The hot air popcorn popper represents a product that handles a wide array of input and output flows and, thus, requires a broad language to describe its function. The product is shown in Fig. 5.

The unstructured functional model of the popcorn popper is shown in Fig. 6 (referred to as FM A henceforth) and the functional basis model is shown in Fig. 7 (referred to as FM B henceforth). Note that FM B is less complex overall with fewer sub-functions than FM A (21 vs. 25). This reduction in complexity is made possible by the standard set of functions and flows and standard level of detail of the functional basis. For other products tasks, the conversion with the functional model may actually increase the number of sub-functions. In such cases, the model is being made more consistent and physically correct. Next, we compare the two functional models flow by flow.

Flow: Air (Gas). In FM A, the popcorn popper *captures, stores, moves, channels* and *heats* the air before it splits to deal with the popcorn and butter subassemblies. FM B offers a simpler description of this process. Based on the function definitions, the product does not *store* air. The sub-functions *move air* and *channel air* in FM A are described by *transport air* in FM B, produc-

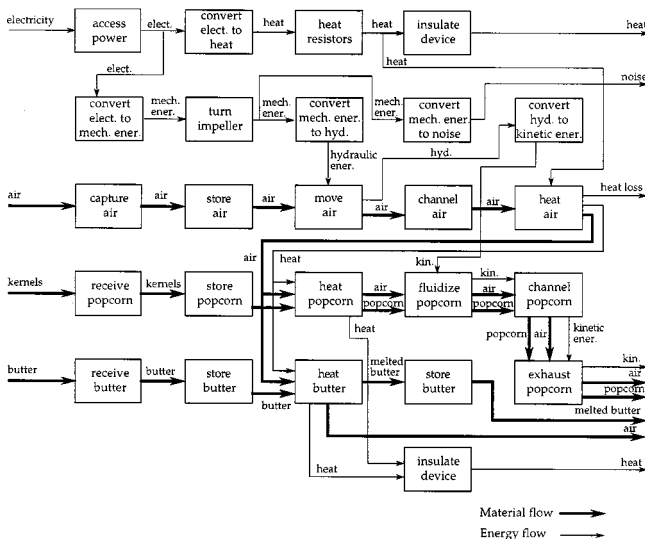

Fig. 6 Functional model of the hot air popcorn popper generated without a structured vocabulary (FM A)

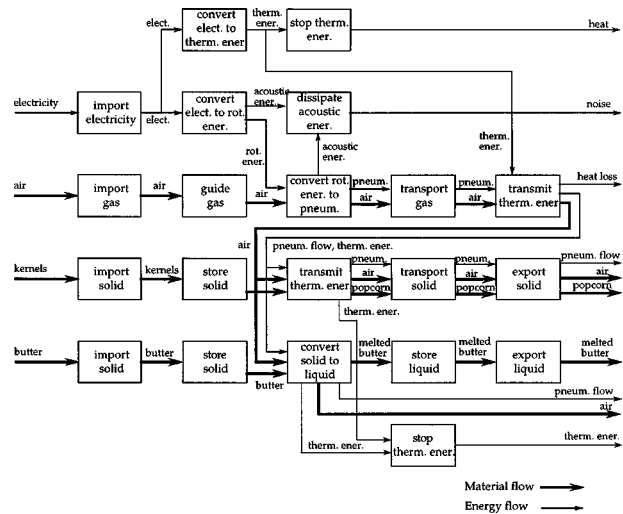

Fig. 7 Functional model of the hot air popcorn popper generated using the functional basis (FM B)

ing a further reduction in total sub-functions and a more consistent level of detail. Also, note that FM B uses the flow *gas* to describe the air. This generalization allows the popcorn popper's functional model to be compared with other products that operate on gases, opening up design by analogy opportunities.

Flow: Electricity. In both models, electricity enters the system (*access power* in FM A, *import electricity* in FM B) and then splits to power the heating and forced air subsystems. For the heating subsystem, FM A presents an overly specific chain of sub-functions: *convert electricity to heat, heat resistors* and *heat air*. Whereas the use of the flow *electricity* indicates a process choice (i.e. electrical energy vs., say, hydraulic energy) the sub-function *heat resistors* indicates a form solution, which should not be present in a functional model. The functional basis prevents this in FM B by generating the sub-function chain *convert electricity to thermal energy* and *transmit thermal energy*.

For the forced air subsystem, FM A again gives an overly specific level of detail. The conversion of electricity to its eventual form of pneumatic kinetic energy requires five sub-functions. FM B describes this in two sub-functions at a more consistent level of detail.

Flow: Kernels (Solid). The sub-function chain dealing with the kernels (which eventually become popcorn) are similar in both models. FM A uses two sub-functions (*fluidize popcorn* and *channel popcorn*) to do what the functional basis defines as *transport solid* in FM B. FM B also refers to the kernel and popcorn as solids in its more general sub-function descriptions.

Flow: Butter (Solid & Liquid). FM A develops a four sub-function chain to operate on the flow of butter: *receive butter, store butter, heat butter* and *store butter*. The two *store butter* sub-functions imply that the same function is needed twice. In fact, as FM B shows in its five sub-function chain (*import solid, store solid, convert solid to liquid, store liquid* and *export liquid*), these are two different functions—*store liquid* and *store solid*. This is an instance where FM B provides more detail than FM A, but at a consistent level.

Example Summary. In sum, this example illustrates two key advantages of the functional basis: a consistent level of detail and semantic uniformity. The standard vocabulary of the functional basis provides a consistent level of detail in sub-function description. This eliminates the proclivity of a design team to bias a functional model with form solutions. The function and flow definitions offer semantic uniformity. For example, FM A uses three

different function words to describe the act of bringing in a flow to the system: *access*, *capture* and *receive*. This is the same function, more aptly named *import* in the functional basis. By arriving at this consistent representation, analogies across many product domains may be sought that solve the import function. Likewise, design histories may be archived and retrieved for future use and study.

7 Concluding Remarks

The functional basis provides a common design language that can be used to model the functionality of products or processes. Our current focus is to develop a functional modeling language for human analysis and communication. In the future, a formal computable form of the functional basis is desired. The adoption of the functional basis will allow different designers to share information at the same level of detail, to generate repeatable function structures, and to compare functionality of different products for idea generation purposes. All of these features contribute to an overall goal of formulating engineering design as a set of systematic and repeatable principles and as a teachable content area. We are not advocating, here, that design does not include artistic and creative aspects. Such aspects are at the core of product design. Instead, we are advocating a position where many tasks in design may be executed in a systematic and repeatable manner. Formalisms such as a functional basis aid in making methods systematic and repeatable, enhancing the innovations that may be generated.

While the inductive functional basis presented here is intended to span the entire mechanical design space, future efforts should address its validity regardless of product scale and its applicability to disciplines outside of mechanical design. The products included in this research have been small to medium scale, across a variety of industries. Large scale systems, such as automobiles, aircraft, and the like are on the horizon.

Acknowledgments

The authors appreciate the careful review of this work by Dr. Rob Redfield, US Air Force Academy. In addition, this work is supported by the National Science Foundation under a NSF Young Investigator Award, Ford Motor Company, Desktop Manufacturing Corporation, Texas Instruments, W.M. Keck Foundation, the June and Gene Gillis Endowed Faculty Fellow in Manufacturing and the University of Missouri Research Board. Any opinions or findings of this work are the responsibility of the authors, and do not necessarily reflect the views of the sponsors or collaborators.

Appendix A: Flow Definitions

The set of flow definitions that follow is part of the functional basis described in Section 4. A flow from this list is selected to fill the object position of the verb-object functional description. Flows in the functional basis are more abstract representations of the actual problem's flows. The given definitions make the transformation from actual flow to basis flow more methodical and repeatable. An example of the flow usage follows each definition.

1 Material

- (a) **Human.** All or part of a person who crosses the device boundary. Example: Most coffee makers require the flow of a *human hand* to actuate (or start) the electricity and thus heat the water.
- (b) **Solid.** Any object with mass having a definite, firm shape. Example: The flow of sand paper into a hand sander is transformed into a *solid* entering the sander.
- (c) **Liquid.** A readily flowing fluid, specifically having its molecules moving freely with respect to each other, but because of cohesive forces, not expanding indefinitely. Example: The flow of water through a coffee maker is a *liquid*.

- (d) **Gas.** Any collection of molecules which are characterized by random motion and the absence of bonds between the molecules. Example: An oscillating fan moves air by rotating blades. The air is transformed as *gas* flow.

2 Energy

- (a) **Human.** Work performed by a person on a device. Example: An automobile requires the flow of *human energy* to steer and accelerate the vehicle.
 - i. **Force.** Human effort that is input to the system without regard for the required motion. Example: *Human force* is needed to actuate the trigger of a toy gun.
 - ii. **Motion.** Activity requiring movement of all or part of the body through a prescribed path. Example: The trackpad on a laptop computer receives the flow of *human motion* to control the cursor.
- (b) **Acoustic.** Work performed in the production and transmission of sound. Example: The motor of a power drill generates the flow of *acoustic energy* in addition to the torque.
 - i. **Pressure.** The pressure field of the sound waves. Example: A condenser microphone has a diaphragm which vibrates in response to *acoustic pressure*. This vibration changes the capacitance of the diaphragm, thus superimposing an alternating voltage on the direct voltage applied to the circuit.
 - ii. **Particle velocity.** The speed at which sound waves travel through a conducting medium. Example: Sonar devices rely on the flow of *acoustic particle velocity* to determine the range of an object.
- (c) **Biological.** Work produced by or connected with plants or animals. Example: In poultry houses, grain is fed to chickens which is then converted into *biological energy*.
 - i. **Pressure.** The pressure field exerted by a compressed biological fluid. Example: The high concentration of sugars and salts inside a cell causes the entry, via osmosis, of water into the vacuole, which in turn expands the vacuole and generates a hydrostatic *biological pressure*, called turgor, that presses the cell membrane against the cell wall. Turgor is the cause of rigidity in living plant tissue.
 - ii. **Volumetric flow.** The kinetic energy of molecules in a biological fluid flow. Example: Increased metabolic activity of tissues such as muscles or the intestine automatically induces increased *volumetric flow* of blood through the dilated vessels.
- (d) **Chemical.** Work resulting from the reactions by which substances are produced from or converted into other substances. Example: A battery converts the flow of *chemical energy* into electrical energy.
 - i. **Affinity.** The force with which atoms are held together in chemical bonds. Affinity is proportional to the chemical potential of a compound's constituent species. Example: An internal combustion engine transforms the *chemical affinity* of the gas into a mechanical force.
 - ii. **Reaction rate.** The speed or velocity at which chemical reactants produce products. Reaction rate is proportional to the mole rate of the constituent species. Example: Special coatings on automobile panels stop the *chemical reaction rate* of the metal with the environment.
- (e) **Electrical.** Work resulting from the flow of electrons from a negative to a positive source. Example: A power belt sander imports a flow of *electrical energy* (*electricity*, for convenience) from a wall outlet and transforms it into a rotation.

- i. **Electromotive force.** Potential difference across the positive and negative sources. Example: Household electrical receptacles provide a flow of *electromotive force* of approximately 110 V.
 - ii. **Current.** The flow or rate of flow of electric charge in a conductor or medium between two points having a difference in potential. Example: Circuit breakers trip when the *current* exceeds a specified limit.
- (f) **Electromagnetic.** Energy that is propagated through free space or through a material medium in the form of electromagnetic waves (Britannica Online, 1997). It has both wave and particle-like properties. Example: Solar panels convert the flow *electromagnetic energy* into electricity.
- i. **Optical.** Work associated with the nature and properties of light and vision. Also, a special case of solar energy (see **solar**). Example: A car visor refines the flow of *optical energy* that its passengers receive.
 - (a) **Intensity.** The amount of optical energy per unit area. Example: Tinted windows reduce the *optical intensity* of the entering light.
 - (b) **Velocity.** The speed of light in its conducting medium. Example: NASA developed and tested a trajectory control sensor (TCS) for the space shuttle to calculate the distance between the payload bay and a satellite. It relied on the constancy of the *optical velocity* flow to calculate distance from time of flight measurements of a reflected laser.
 - ii. **Solar.** Work produced by or coming from the sun. Example: Solar panels collect the flow of *solar energy* and transform it into electricity.
 - (a) **Intensity.** The amount of solar energy per unit area. Example: A cloudy day reduces the *solar intensity* available to solar panels for conversion to electricity.
 - (b) **Velocity.** The speed of light in free space. Example: Unlike most energy flows, *solar velocity* is a well known constant.
- (g) **Hydraulic.** Work that results from the movement and force of a liquid, including hydrostatic forces. Example: Hydroelectric dams generate electricity by harnessing the *hydraulic energy* in the water that passes through the turbines.
- i. **Pressure.** The pressure field exerted by a compressed liquid. Example: A hydraulic jack uses the flow *hydraulic pressure* to lift heavy objects.
 - ii. **Volumetric flow.** The movement of fluid molecules. Example: A water meter measures the *volumetric flow* of water without a significant pressure drop in the line.
- (h) **Magnetic.** Work resulting from materials that have the property of attracting other like materials, whether that quality is naturally occurring or electrically induced. Example: The *magnetic energy* of a magnetic lock is the flow that keeps it secured to the iron based structure.
- i. **Magnetomotive force.** The driving force which sets up the magnetic flux inside of a core. Magnetomotive force is directly proportional to the current in the coil surrounding the core. Example: In a magnetic door lock, a change in *magnetomotive force* (brought about by a change in electrical current) allows the lock to disengage and the door to open.
 - ii. **Magnetic flux rate.** Flux is the magnetic displacement variable in a core induced by the flow of current through a coil. The magnetic flow variable is the time rate of change of the flux. The voltage across a magnetic coil is directly proportional to the time rate of change of magnetic flux. Example: A magnetic relay is a transducer that senses the *time rate of change of magnetic flux* when the relay arm moves.
- (i) **Mechanical.** Energy associated with the moving parts of a machine or the strain energy associated with a loading state of an object. Example: An elevator converts electrical or hydraulic energy into *mechanical energy*.
- i. **Rotational energy.** Energy that results from a rotation or a virtual rotation. Example: Customers are primarily concerned with the flow of *rotational energy* from a power screwdriver.
 - (a) **Torque.** Pertaining to the moment that produces or tends to produce rotation. Example: In a power screwdriver, electricity is converted into *rotational energy*. The more specific flow is *torque*, based on the primary customer need to insert screws easily, not quickly.
 - (b) **Angular velocity.** Pertaining to the orientation or the magnitude of the time rate of change of angular position about a specified axis. Example: A centrifuge is used to separate out liquids of different densities from a mixture. The primary flow it produces is that of *angular velocity*, since the rate of rotation about an axis is the main concern.
 - ii. **Translational energy.** Energy flow generated or required by a translation or a virtual translation. Example: A child's toy, such as a projectile launcher, transmits *translational energy* to the projectile to propel it away.
 - (a) **Force.** The action that produces or attempts to produce a translation. Example: In a tensile testing machine, the primary flow of interest is that of a *force* which produces a stress in the test specimen.
 - (b) **Linear velocity.** Motion that can be described by three component directions. Example: An elevator car uses the flow of *linear velocity* to move between floors.
 - iii. **Vibrational energy.** Oscillating translational or rotational energy that is characterized by an amplitude and frequency. In the rotational case, motion does not complete a 360° cycle (if >360°, then use **rotational energy** category). Example: In many block sanders, the sanding surface receives a flow of *vibration* to remove the wood surface. *Vibration* is produced by an offcenter mass on the motor shaft.
 - (a) **Amplitude.** Energy flow is characterized by the magnitude of the generalized force or displacement. Example: In fatigue testing, the *vibrational amplitude* of the tensile stress is more important than the speed of each loading cycle.
 - (b) **Frequency.** Energy flow is characterized by the number of oscillatory cycles per unit time. Example: Exposure to certain *vibrational frequencies* can induce sickness in humans.
- (j) **Pneumatic.** Work resulting from a compressed gas flow or pressure source. Example: A B-B gun relies on the flow of *pneumatic energy* (from compressed air) to propel the projectile (B-B).
- i. **Pressure.** The pressure field exerted by a compressed gas. Example: Certain cylinders rely on the flow of *pneumatic pressure* to move a piston or support a force.
 - ii. **Mass flow.** The kinetic energy of molecules in a gas flow. Example: The *mass flow* of air is the flow that transmits the thermal energy of a hair dryer to damp hair.

- (k) **Radioactive.** Work resulting from or produced by particles or rays, such as alpha, beta and gamma rays, by the spontaneous disintegration of atomic nuclei. Example: Nuclear reactors produce a flow of *radioactive energy* which heats water into steam and then drives electricity generating turbines.
 - i. **Intensity.** The amount of radioactive particles per unit area. Example: Concrete is an effective radioactive shielding material, reducing the *radioactive intensity* in proportion to its thickness.
 - ii. **Decay rate.** The rate of emission of radioactive particles from a substance. Example: The *decay rate* of carbon provides a method to date pre-historic objects.
- (l) **Thermal.** A form of energy that is transferred between bodies as a result of their temperature difference. Example: A coffee maker converts the flow of electricity into the flow of *thermal energy* which it transmits to the water.

Note: A pseudo bond graph approach is used here. The true effort and flow variables are temperature and the time rate of change of entropy. However, a more practical pseudo-flow of heat rate is chosen here.

 - i. **Temperature.** The degree of heat of a body. Example: A coffee maker brings the *temperature* of the water to boiling in order to siphon the water from the holding tank to the filter basket.
 - ii. **Heat rate.** (Note: this is a pseudo-flow.) The time rate of change of heat energy of a body. Example: Fins on a motor casing increase the flow *heat rate* from the motor by conduction (through the fin), convection (to the air) and radiation (to the environment).

3 Signal

- (a) **Status.** A condition of some system, as in information about the state of the system. Example: Automobiles often measure the engine water temperature and send a *status signal* to the driver via a temperature gage.
 - i. **Auditory.** A condition of some system as displayed by a sound. Example: Pilots receive an *auditory signal*, often the words “pull up,” when their aircraft reaches a dangerously low altitude.
 - ii. **Olfactory.** A condition of some system as related by the sense of smell or particulate count. Example: Carbon monoxide detectors receive an *olfactory signal* from the environment and monitor it for high levels of CO.
 - iii. **Tactile.** A condition of some system as perceived by touch or direct contact. Example: A pager delivers a *tactile signal* to its user through vibration.
 - iv. **Taste.** A condition of some dissolved substance as perceived by the sense of taste. Example: In an electric wok, the *taste signal* from the human chef is used to determine when to turn off the wok.
 - v. **Visual.** A condition of some system as displayed by some image. Example: A power screwdriver provides a *visual signal* of its direction through the display of arrows on the switch.
- (b) **Control.** A command sent to an instrument or apparatus to regulate a mechanism. Example: An airplane pilot sends a *control signal* to the elevators through movement of the yoke. The yoke movement is transformed into an electrical signal, sent through wiring to the elevator, and then transformed back into a physical elevator deflection.

Appendix B: Function Definitions

The function classes are introduced in Section 4. Definitions for each class and basic function are presented below. Examples are given for the basic functions. Used with the flow definitions of

Appendix A, the function definitions complete the functional basis, improving repeatability of function structure development and providing a standard level of detail at which the decomposition process stops.

1 **Branch.** To cause a material or energy to no longer be joined or mixed.

- (a) **Separate.** To isolate a material or energy into distinct components. The separated components are distinct from the flow before separation, as well as each other. Example: A glass prism *separates* light into different wavelength components to produce a rainbow.
 - i. **Remove.** To take away a part of a *material* from its prefixed place. Example: A sander *removes* small pieces of the wood surface to smooth the wood.
- (b) **Refine.** To reduce a material or energy such that only the desired elements remain. Example: In a coffee maker, the filter *refines* the coffee grounds and allows the new liquid (coffee) to pass through.
- (c) **Distribute.** To cause a material or energy to break up. The individual bits are similar to each other and the undistributed flow. Example: An atomizer *distributes* (or sprays) hair-styling liquids over the head to hold the hair in the desired style.

2 **Channel.** To cause a material or energy to move from one location to another location.

- (a) **Import.** To bring in an energy or material from outside the system boundary. Example: A physical opening at the top of a blender pitcher *imports* a solid (food) into the system. Also, a handle on the blender pitcher *imports* a human hand. The blender system *imports* electricity via an electric plug.
- (b) **Export.** To send an energy or material outside the system boundary. Example: Pouring blended food out of a standard blender pitcher *exports* liquid from the system. The opening at the top of the blender is a solution to the *export* sub-function.
- (c) **Transfer.** To shift, or convey, a flow from one place to another.
 - i. **Transport.** To move a *material* from one place to another. Example: A coffee maker *transports* liquid (water) from its reservoir through its heating chamber and then to the filter basket.
 - ii. **Transmit.** To move an *energy* from one place to another. Example: In a hand held power sander, the housing of the sander *transmits* human force to the object being sanded.
- (d) **Guide.** To direct the course of an energy or material along a specific path. Example: A domestic HVAC system *guides* gas (air) around the house to the correct locations via a set of ducts.
 - i. **Translate.** To fix the movement of a *material* (by a device) into one linear direction. Example: In an assembly line, a conveyor belt *translates* partially completed products from one assembly station to another.
 - ii. **Rotate.** To fix the movement of a *material* (by a device) around one axis. Example: A computer disk drive *rotates* the magnetic disks around an axis so that data can be read by the head.
 - iii. **Allow degree of freedom (DOF).** To control the movement of a *material* (by a force external to the device) into one or more directions. Example: To provide easy trunk access and close appropriately, trunk lids need to move along a specific degree of freedom. A four bar linkage *allows* a rotational *DOF* for the trunk lid.

- 3 **Connect.** To bring two or more energies or materials together.
- Couple.** To join or bring together energies or materials such that the members are still distinguishable from each other. Example: A standard pencil *couples* an eraser and a writing shaft. The coupling is performed using a metal sleeve that is crimped to the eraser and the shaft.
 - Mix.** To combine two materials into a single, uniform homogeneous mass. Example: A shaker *mixes* a paint base and its dyes to form a homogeneous liquid.
- 4 **Control Magnitude.** To alter or govern the size or amplitude of material or energy.
- Actuate.** To commence the flow of energy or material in response to an imported control signal. Example: A circuit switch *actuates* the flow of electrical energy and turns on a light bulb.
 - Regulate.** To adjust the flow of energy or material in response to a control signal, such as a characteristic of a flow. Example: Turning the valves *regulates* the flow rate of the liquid flowing from a faucet.
 - Change.** To adjust the flow of energy or material in a pre-determined and fixed manner. Example: In a hand held drill, a variable resistor *changes* the electrical energy flow to the motor thus changing the speed the drill turns.
 - Form.** To mold or shape a material. Example: In the auto industry, large presses *form* sheet metal into contoured surfaces that become fenders, hoods and trunks.
 - Condition.** To render an energy appropriate for the desired use. Example: To prevent damage to electrical equipment, a surge protector *conditions* electrical energy by excluding spikes and noise (usually through capacitors) from the energy path.
- 5 **Convert.** To change from one form of energy or material to another. For completeness, any type of flow conversion is valid. In practice, conversions such as *convert electricity to torque* will be more common than *convert solid to optical energy*. Example: An electrical motor *converts* electricity to rotational energy.
- 6 **Provide.** To accumulate or provide material or energy.
- Store.** To accumulate material or energy. Example: A DC electrical battery *stores* the energy in a flashlight.
 - Supply.** To provide material or energy from storage. Example: In a flashlight, the battery *supplies* energy to the bulb.
 - Extract.** To draw, or forcibly pull out, a material or energy. Example: Metal wire is *extracted* from the manufacturing process of extrusion.
- 7 **Signal.** To provide information.
- Sense.** To perceive, or become aware, of a signal. Example: An audio cassette machine *senses* if the end of the tape has been reached.
 - Indicate.** To make something known to the user. Example: A small window in the water container of a coffee maker *indicates* the level of water in the machine.
 - Display.** To show a visual effect. Example: The face and needle of an air pressure gage *display* the status of the pressure vessel.
 - Measure.** To determine the magnitude of a material or energy flow. Example: An analog thermostat *measures* temperature through a bimetallic strip.
- 8 **Support.** To firmly fix a material into a defined location, or secure an energy into a specific course.
- Stop.** To cease, or prevent, the transfer of a material or energy. Example: A reflective coating on a window *stops* the transmission of UV radiation through a window.
 - Stabilize.** To prevent a material or energy from changing course or location. Example: On a typical canister vacuum, the center of gravity is placed at a low elevation to *stabilize* the vacuum when it is pulled by the hose.
 - Secure.** To firmly fix a material or energy path. Example: On a bicycling glove, a velcro strap *secures* the human hand in the correct place.
 - Position.** To place a material or energy into a specific location or orientation. Example: The coin slot on a soda machine *positions* the coin to begin the coin evaluation and transportation procedure.

References

- Stone, R., Wood, K., and Crawford, R., 1998, "A Heuristic Method to Identify Modules from a Functional Description of a Product," *Proceedings of DETC98*, DETC98/DTM-5642, Atlanta, GA.
- Stone, R., Wood, K., and Crawford, R., 2000, "A Heuristic Method for Identifying Modules for Product Architectures," *Des. Stud.*, **21**, No. 1, pp. 5–31.
- Ullman, D., 1997, *The Mechanical Design Process*, 2nd ed., McGraw-Hill, New York.
- Pahl, G., and Beitz, W., 1988, *Engineering Design: A Systematic Approach*, Springer-Verlag, Berlin.
- Suh, N., 1990, *The Principles of Design*, Oxford University Press.
- Hubka, V., and Ernst Eder, W., 1984, *Theory of Technical Systems*, Springer-Verlag, Berlin.
- Ulrich, K., and Eppinger, S., 1995, *Product Design and Development*, McGraw-Hill, New York.
- Schmidt, L., and Cagan, J., 1995, "Recursive Annealing: A Computational Model for Machine Design," *Res. Eng. Des.*, **7**, pp. 102–125.
- Pimpler, T., and Eppinger, S., 1994, "Integration Analysis of Product Decompositions," *Proceedings of the ASME Design Theory and Methodology Conference*, DE-Vol. 68.
- Shimomura, Y., Tanigawa, S., Takeda, H., Umeda, Y., and Tomiyama, T., 1996, "Functional Evaluation Based on Function Content," *Proceedings of the 1996 ASME Design Theory and Methodology Conference*, 96-DETC/DTM-1532, Irvine, CA.
- Cutherell, D., 1996, "Chapter 16: Product Architecture," *The PDMA Handbook of New Product Development*, Rosenau, M., Jr., et al., ed., Wiley, New York.
- Otto, K., and Wood, K. L., 1998, "Reverse Engineering and Redesign Methodology," *Res. Eng. Des.*, **10**, No. 4, pp. 226–243.
- Otto, K., and Wood, K., 1997, "Conceptual and Configuration Design of Products and Assemblies," *ASM Handbook, Materials Selection and Design*, **20**, ASM International.
- Akiyama, K., *Function Analysis: Systematic Improvement of Quality Performance*, Productivity Press, 1991.
- Miles, L., 1972, *Techniques of Value Analysis Engineering*, McGraw-Hill, New York.
- VAI (Value Analysis Incorporated), *Value Analysis, Value Engineering, and Value Management*, Clifton Park, New York, 1993.
- Collins, J., Hagan, B., and Bratt, H., 1976, "The Failure-Experience Matrix—a Useful Design Tool," *ASME J. Eng. Ind.*, **98**, pp. 1074–1079.
- Hundal, M., 1990, "A Systematic Method for Developing Function Structures, Solutions and Concept Variants," *Mech. Mach. Theory*, **25**, No. 3, pp. 243–256.
- Koch, P., Peplinski, J., Allen, J., and Mistree, F., 1994, "A Method for Design Using Available Assets: Identifying a Feasible System Configuration," *Behav. Sci.*, **30**, pp. 229–250.
- Malmqvist, J., Axelsson, R., and Johansson, M., 1996, "A Comparative Analysis of the Theory of Inventive Problem Solving and the Systematic Approach of Pahl and Beitz," *Proceedings of the 1996 ASME Design Engineering Technical Conferences*, 96-DETC/DTM-1529, Irvine, CA.
- Altshuller, G., 1984, *Creativity as an Exact Science*, Gordon and Breach Publishers.
- Kirschman, C., Fadel, G., 1998, "Classifying Functions for Mechanical Design," *ASME J. Mech. Des.*, **120**, No. 3, pp. 475–482.
- Little, A., Wood, K., and McAdams, D., 1997, "Functional Analysis: A Fundamental Empirical Study for Reverse Engineering, Benchmarking and Redesign," *Proceedings of the 1997 Design Engineering Technical Conferences*, 97-DETC/DTM-3879, Sacramento, CA.
- Little, A., 1997, "A Reverse Engineering Toolbox for Functional Product Measurement," Master thesis, The University of Texas at Austin.
- Murdock, J., Szykman, S., and Sriram, R., 1997, "An Information Modeling Framework to Support Design Databases and Repositories," *Proceedings of DETC'97*, DETC97/DFM-4373, Sacramento, CA.
- McAdams, D., Stone, R., and Wood, K., 1998, "Product Similarity Based on Customer Needs," *Proceedings of DETC98*, DETC98/DTM-5660, Atlanta, GA.
- McAdams, D., Stone, R., and Wood, K., 1999, "Functional Interdependence and Product Similarity based on Customer Needs," *Res. Eng. Des.*, **11**, No. 1, pp. 1–19.

- [28] Stone, R., 1997, “*Towards a Theory of Modular Design*,” Doctoral thesis, The University of Texas at Austin.
- [29] Karnop, D., Margolis, D., and Rosenberg, R., 1990, *System Dynamics: A Unified Approach*, Wiley, New York.
- [30] Karnop, D., 1990, “Bond Graph Models for Electrochemical Energy Storage: Electrical, Chemical and Thermal Effects,” *J. Franklin Inst.*, **327**, No. 6, pp. 982–992.
- [31] Breedveld, P., Rosenberg, R., and Zhou, T., eds., 1991, “Bibliography of Bond Graph Theory and Application,” *J. Franklin Inst.*, **328**, No. 5, pp. 1067–1109.
- [32] Tipler, P., 1978, *Modern Physics*, Worth Publishers.
- [33] U.S. Department of Transportation, 1996, “Human Factors Design Guide,” Federal Aviation Administration, DOT/FAA/CT-96/1, Atlantic City, NJ.
- [34] Urban, G., and Hauser, J., 1993, *Design and Marketing of New Products*, 2nd ed., Prentice Hall, New York.