

# 976nm, Fiber-Coupled, Single Emitter Module

## Features

- Compact size
- Detachable SMA-fiber 200 $\mu$ m
- TEC for temperature stabilizing
- Thermistor

## Options

- 650nm pilot laser (aiming laser)
- Monitor photodiode
- Fiber detection sensor



## Device Specification

Optical Parameters <sup>1</sup>	Units	
Center Wavelength Range <sup>3</sup>	nm	976
Center Wavelength Tolerance	nm	$\pm 10$
Output Power <sup>2</sup>	W	10
Spectral Width (FWHM)	nm	<6
Slope Efficiency	W/A	>0.7
Wavelength Temp. Coefficient	nm/ $^{\circ}$ C	$\sim 0.38$

Fiber Parameters	Units	
Fiber Core Diameter	$\mu$ m	200
Numerical Aperture	NA	0.22
Fiber Connector		SMA-905

Pilot Laser (Aiming Laser)	Units	
Output Power	mW	<0.5
Wavelength	Nm	650 $\pm 10$
Voltage	V	3.5
Current	mA	<30

Electrical Parameters <sup>1</sup>		
Power Conversion Efficiency	%	>25
Threshold Current ( $I_{TH}$ )	A	0.5 to 1.8
Operating Current ( $I_{OP}$ )	A	<14
Operating Voltage ( $V_{OP}$ )	V	<2.5
Current Monitoring Photo Diode ( $I_{mo}$ )	mA	0.1 to 0.5
TEC max. Current ( $I_t$ )	A	6.0
TEC max. Voltage ( $U_t$ )	V	9.8
Thermistor Data ( $R_t$ )	k $\Omega/\beta(25^{\circ}$ C)	10 $\pm 5\%$ / 4100

Thermal Parameters		
Operating Temperature Range <sup>3, 4</sup>	$^{\circ}$ C	+20 to +30
Storage Temperature Range <sup>4</sup>	$^{\circ}$ C	0 to +55
Recommended Heatsink Capacity	W	35
Max. Soldering Temperature for Electrical Leads	$^{\circ}$ C	220
Max. Soldering Time per Lead	s	10

<sup>1</sup>Data at 25 $^{\circ}$ C thermistor temperature

<sup>2</sup>Reduced lifetime if used above nominal operating conditions

<sup>3</sup>Others available upon request

<sup>4</sup>A non-condensing environment is required for storage and operation below the ambient dew point

# 976nm, Fiber-Coupled, Single Emitter Module

## Package Dimension

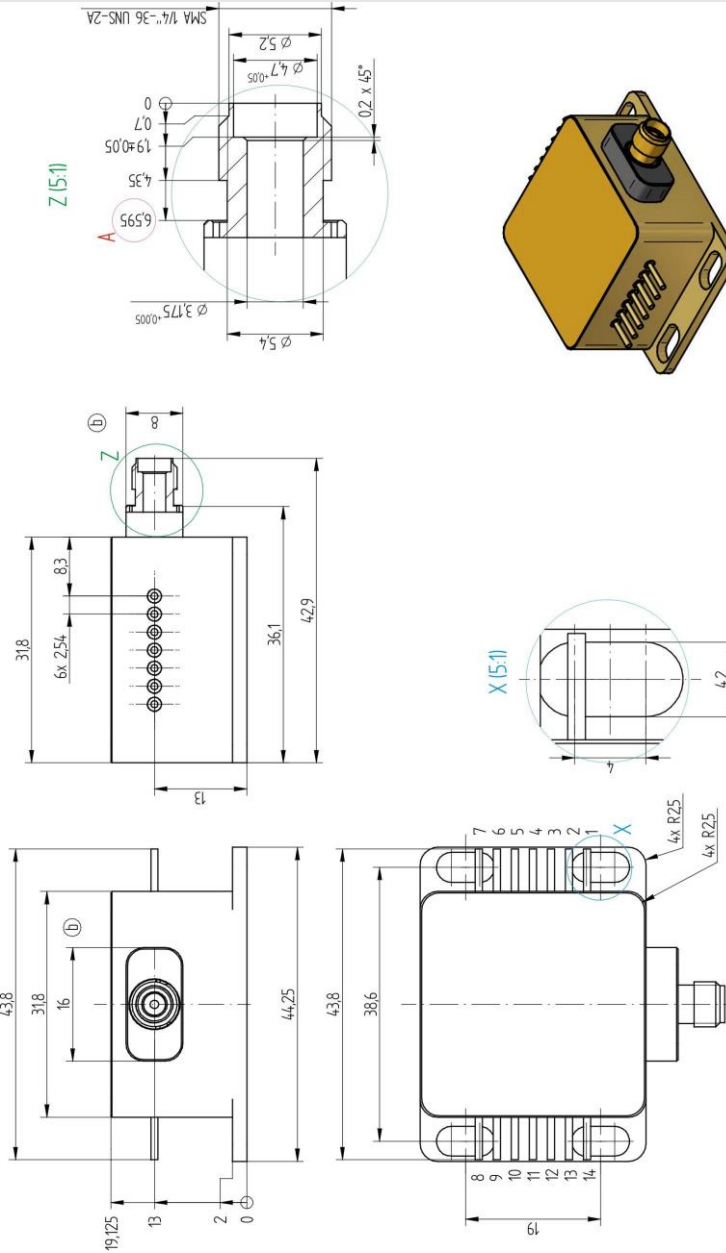

## Pin Assignment

- 1 = Metal housing, GND
- 2 = Laser diode (+)
- 3 = Temperature sensor (NTC)
- 4 = Temperature sensor (NTC)
- 5 = Laser diode (-)
- 6 = Power PD, photo diode (+)
- 7 = Power PD, photo diode (-)
- 8 = Thermo-electric cooler (TEC -)
- 9 = Fiber detection PD, photo diode (+)
- 10 = Fiber detection LED (-)
- 11 = Fiber detection common LED (+)/PD (-)
- 12 = Aiming laser (+ 3.5 V)
- 13 = Aiming laser (GND)
- 14 = Thermo-electric cooler (TEC +)



©2013 DILAS. All rights reserved. DILAS reserves the right to change product specifications without notice. For handling precautions, please reference the general handling instruction manual.

For complete details, please contact your local DILAS sales representative or visit our website at [www.DILAS.com](http://www.DILAS.com).

**Europe**  
**DILAS Diodenlaser GmbH**  
Galileo-Galilei-Straße 10  
55129 Mainz  
Germany  
Phone: +49 (0)6131 9226 0  
Fax: +49 (0)6131 9226 257  
Email: [sales@DILAS.de](mailto:sales@DILAS.de)

**North America**  
**DILAS Diode Laser, Inc.**  
9070 South Rita Road  
Suite 1500  
Tucson, AZ 85747  
Phone: +1 (520) 232-3480  
Fax: +1 (520) 232-3499  
Email: [sales@DILAS-INC.com](mailto:sales@DILAS-INC.com)

**China & Taiwan**  
**DILAS Diodenlaser GmbH**  
China Sales Office  
Room 206, Sunplus Technology, Bldg. 2  
No. 1077 Zu Chongzhi Road  
Hi-Tech Park, Shanghai 201203,  
P.R. China  
Phone: +86 (0) 21-6855-2216  
Fax: +86 (0) 21-5027-3793  
Email: [sales@DILAS-CHINA.com.cn](mailto:sales@DILAS-CHINA.com.cn)