

# Power Cube

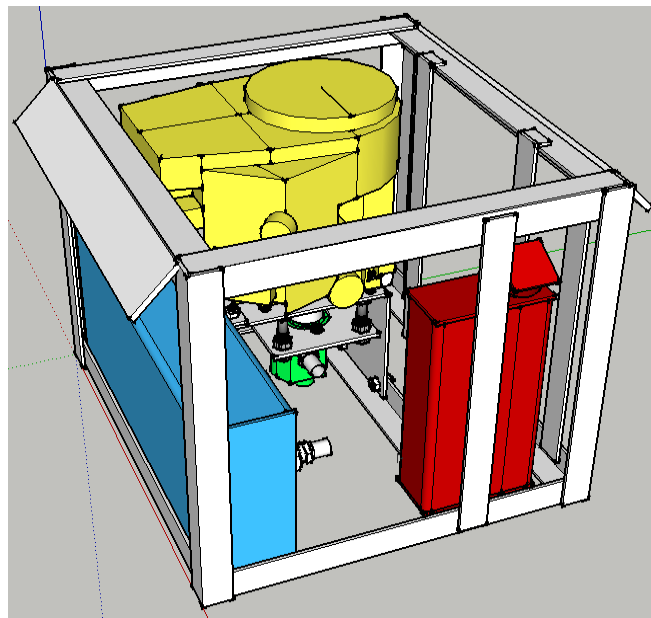

Version 4

## **Contents**

### **Table of Contents**

Power Cube.....	1
Contents.....	2
Introduction.....	3
Bill Of Materials .....	4
Discrete parts.....	4
Steel.....	5
Subassembly Fabrication.....	6
Assembly.....	8
User Guide.....	15

## ***Introduction***

The Power Cube is an universal, self-contained power unit that consists of an engine coupled to a hydraulic pump for providing power in the form of hydraulic fluid at high pressure. It connects via quick couplers and quick-connect hydraulic hoses to devices such as:

▲ LifeTrac



▲ CEB Press



▲ Sawmill



○

This document provides information for building and using a Power Cube as part of the Open Source Ecology (OSE) project.

Check the OSE website for updates to this document:

<http://opensourceecology.org/wiki/File:Powercube.odt>

**Bill Of Materials****Discrete parts**

Name	Qty	Dimensions	Manufacturer / Retailer	Part No.
Engine	1	28 HP	Briggs & Stratton	49M777 Series
Solid Shaft Coupling	1	1 1/8" x 5/8"	Sweiger Shop	Custom
Hydraulic Pump	1	0.976 cu in	SurplusCenter.com	9-1766-B
SAE 10M x 3/4" NPTF Adapter	1	3/4" NPTM	SurplusCenter.com	9-6405-10-12
3/4" NPTF Return Filter & Head	1	20 GPM	SurplusCenter.com	9-059
14 GPM Hydraulic Tank Strainer	1	1 1/2" F x 1" M	SurplusCenter.com	9-7290-100
3/4" NPTM TO 3/4" NPTM 90 Elbow	1	3/4"	SurplusCenter.com	9-5500-10-12
JIC 12M x 3/4 NPTM 90 ELBOW	1	12M x 3/4"	SurplusCenter.com	9-2501-12-12
3/4" Quick Coupler S40-6 F/F	1	3/4"	SurplusCenter.com	928-C
1/4" NPT Quick Coupler S40-2	1	1/4"	SurplusCenter.com	9-6314
1/4 NPTM TO 3/4 NPTF ADAPTER	1	1/4" x 3/4" NPT	SurplusCenter.com	9-5405-12
NPT Weld-In Tank Flange	1	1 1/2"	SurplusCenter.com	9-7843-24
NPT Weld-In Tank Flange	2	3/4"	SurplusCenter.com	9-7843-12
NPT Weld-In Tank Flange	1	1/4"	SurplusCenter.com	9-7843-4
Hose barb	1	1/4" NPTM x 1/4"	SurplusCenter.com	455-AA
1" Hose Barb to SAE 12M Adapter	1	1" Hose x SAE 12M	SurplusCenter.com	9-4604-16-12
1" Hose Barb to 1" NPTM Adapter	1	1" x 1" NPTM	SurplusCenter.com	9-4404-16-16
Hydraulic Suction Hose	1	3'	SurplusCenter.com	9-1279
Hydraulic Oil Cooler	1	Approx 12" x 15"	SweigerShop.com	Custom
JIC 12F X JIC 12F 3000 PSI HYD HOSE	1	3/4" x 12"	SurplusCenter.com	951-2212
3/4" NPT PLASTIC TANK BREATHER	1	3/4"	SurplusCenter.com	9-7957-12
3/4" X 3/4" X 3/4" NPTF TEE	1	3/4" x 3/4" x 3/4"	SurplusCenter.com	9-5605-12-12-12
3/4" NPT HEX NIPPLE	4	3/4"	SurplusCenter.com	9-5404-12-12
JIC 12M x 3/4" NPTM 90 Elbow	1	3/4"	SurplusCenter.com	9-2501-12-12

Name	Qty	Dimensions	Manufacturer / Retailer	Part No.
JIC 12M x JIC 12M UNION	1	JIM 12M	SurplusCenter.com	9-2404-12-12
Solenoid	1		SurplusCenter.com	11-1108
12 Volt radiator fan	1	12" - 14"	Auto Part	
Rubber Fuel Line	1	24"	Auto Part	
Battery	1	5" x 7.5" x 7.5"	Walmart	UIP-7
Galvanized Nipple	4	1"	Home Depot	64310
Galvanized Elbow	2	1"	Home Depot	510-003HN
Galvanized Washer	4	2 1/2"	??	??
Galvanized Round	2	2"	??	??
Teflon Tape	1 roll	1/2" wide	Home Depot	??
1 Gauge Wire	30"	1 gauge	Auto Part	??
1 gauge ring connector	6	1 gauge		
- or -	- or -	- or -	Auto Part	??
Copper tubing	9"	3/8"		
Ignition Switch	1			
12 V Fan Switch	1			
Bolt (Angle iron attach)	4	1/2" x 2" x 12 TPI		
Nut (Angle iron attach)	4	1/2" x 12 TPI		
Washer flat	8	1/2"		
Bolt (Engine mount)	4	1/4" x 2" 16 TPI		
Nut (Engine mount)	4	1/4" x 16 TPI		
Bolt (Hydraulic motor mount)	4	3/4" x 3.5" x 12 TPI		
Nut (Hydraulic motor mount)	8	3/4" 12 TPI		
Lock washer (Hydraulic motor mount)	4	3/4"		
Nut (Fan mount)	4			
Bolt (Fan mount)	4			
Bolt (Solenoid mount)	2			
Tractor Enamel: Glossy Black	1	pint		

## Steel

Type	Thickness	Width	Total Length (rounded up)
Angle	1/4"	2" x 2"	408" (34 ft)
Angle	1/8"	2" x 2"	6"
Plate	1/4"	8"	38" (4ft)

Plate	¼"	2"	120"	(10 ft)
Plate	¼"	6"	24"	(2 ft)
Plate	3/8"	4"	54"	(5 ft)
Tube	¼"	4" x 8"	14 ½"	(2 ft)
Tube	¼"	6" x 12"	27 ½"	(Hydraulic reservoir)
Tube	1/8"	4"	2"	(black pipe)
Tube	1/8"	1 9/16"	12"	(Galvanized Muffler Pipe)
Tube	1/8"	6 cm	14"	(Galvanized Muffler Pipe)
Expanded Steel	13 gauge	12"	22"	(Oil cooler grill)

## Subassembly Fabrication

Many of the items listed in the Bill Of Materials require preparation before use in assembly of the Power Cube. This includes drilling and cutting steel up to 3/8" in thickness. These are the parts for assembling a Power Cube. Parts without special detail are not illustrated.

### 1. Engine and Hydraulic Pump mounts

- a) 1/4" x 8" x 12" Plate
- b) 1/4" x 8" x 9" Plate
- c) 1/4" x 2" x 2" x 8" Angle
- d) 1/4" x 2" x 2" x 29" Angle
- e) 1/4" x 8" x 8" Plate

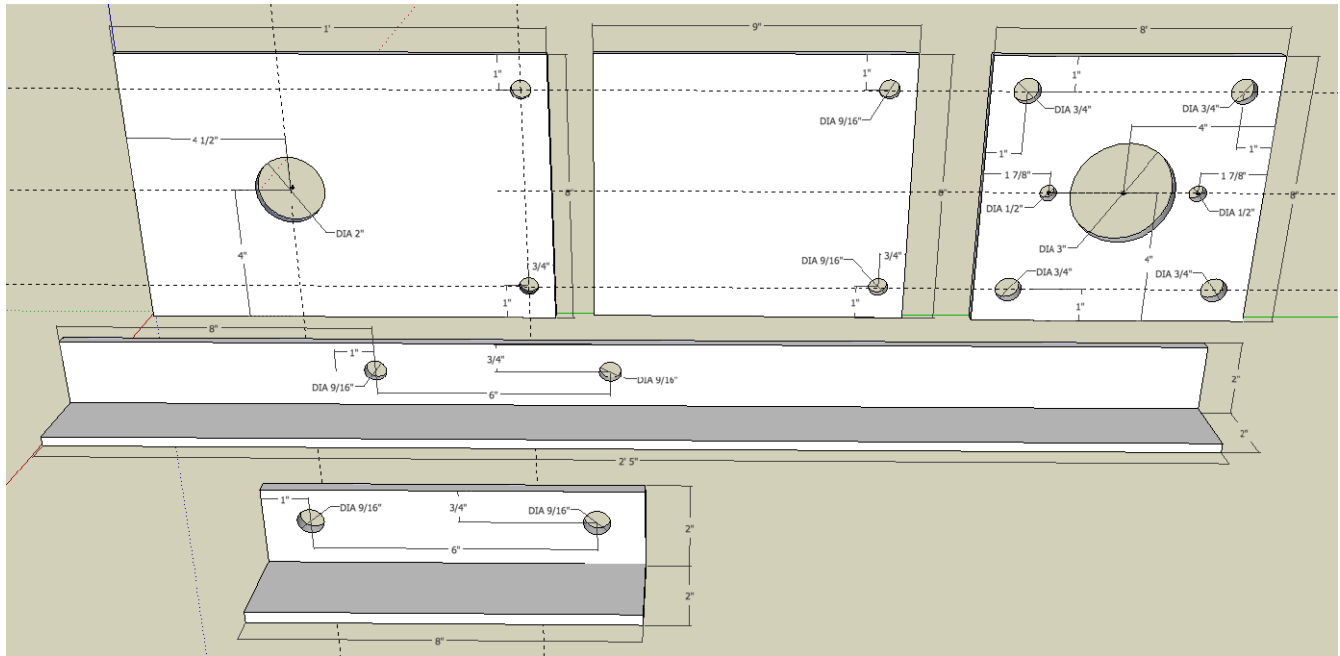

### 2. Quick attach mounts

- a) [2] 3/8" x 4" x 27" Plates



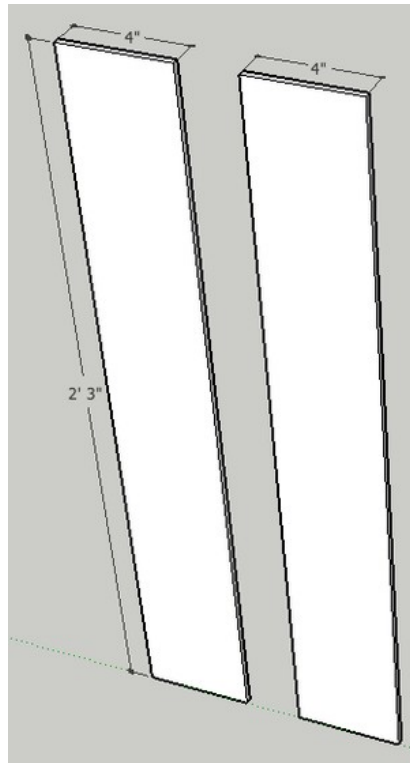

### 3. Fuel tank

- a) [2]  $\frac{1}{4}$ " x 4" x 8" Plates
- b) 4" x 8" x 14  $\frac{1}{2}$ " Tube
- c)  $\frac{1}{4}$ " x 2" x 24" Plate
- d) All welds assembling the tank must be quality welds, as they must not leak. Be careful not to "over weld" the tank to the mount.
- e) Clean the inside of the  $\frac{1}{4}$ " x 4" x 8" tube and the two  $\frac{1}{4}$ " x 4" x 8" plates – anything left on these surfaces will end up in the gasoline and could clog the engine when started. Tack and weld the plates on each end of the tube, taking care to orient the top plate with the filler hole as shown in the diagram below.
- f) Weld the  $\frac{1}{4}$ " tank flange to the hole in the side of the tank tube.

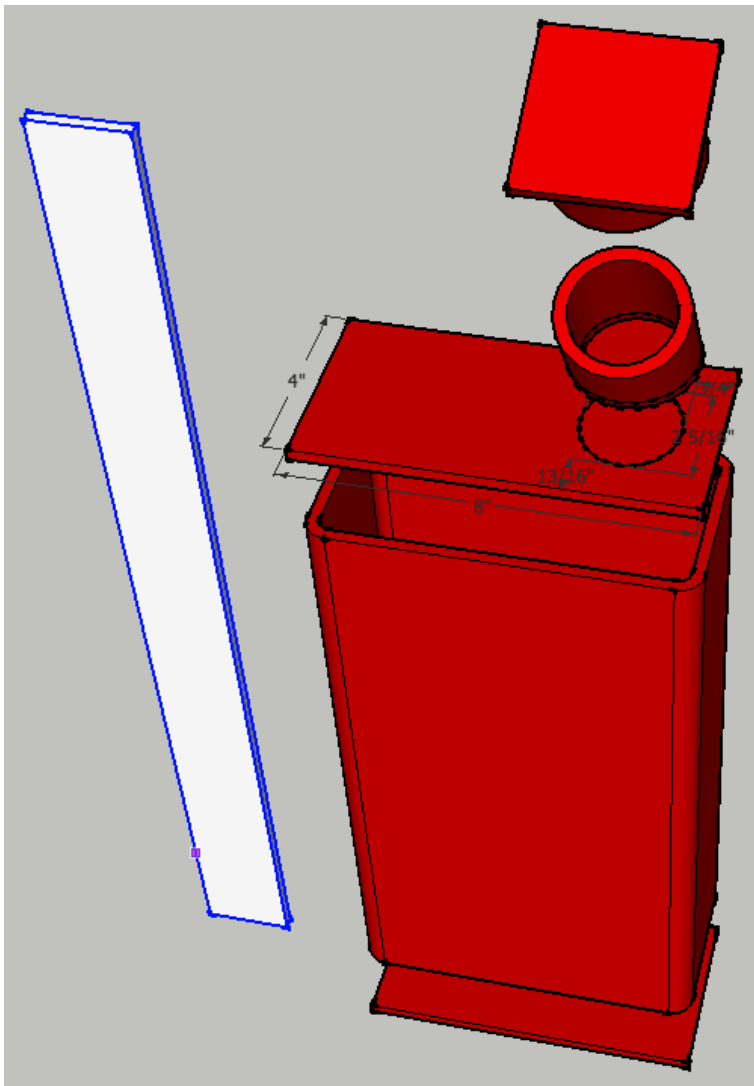

#### 4. Oil Cooler Mount

- a) [2]  $\frac{1}{4}$ " x 2" x 24" Plates
- b) [2]  $\frac{1}{4}$ " x 2" x 1" Plates
- c) [2]  $\frac{1}{4}$ " x 2" x 22" Plates (Note: the holes in these plates may need adjustment based on oil cooler mounting holes)

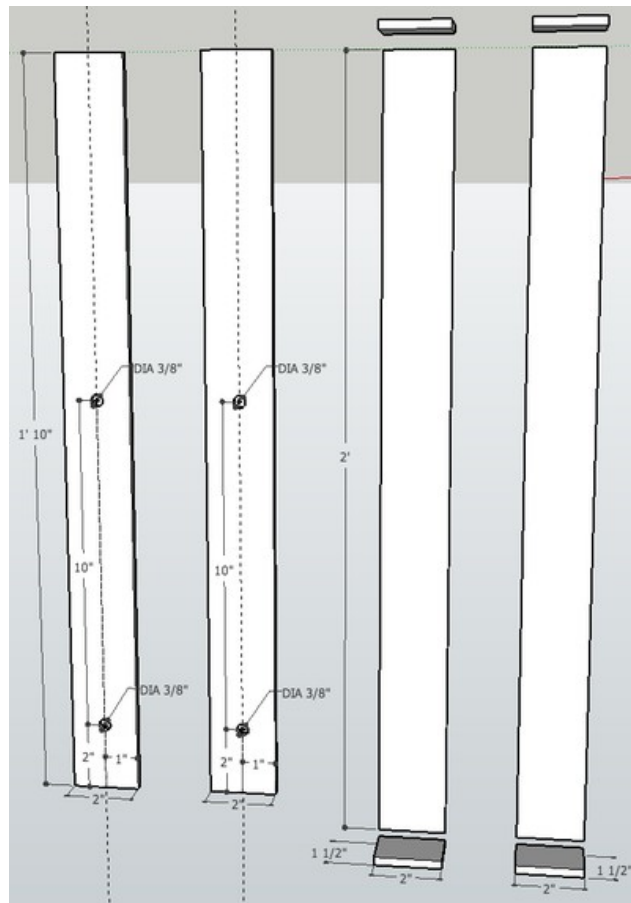

### 5. Key Switches and Choke Brackets

a) [3] 1/8" x 2" x 2" x 2" Angle

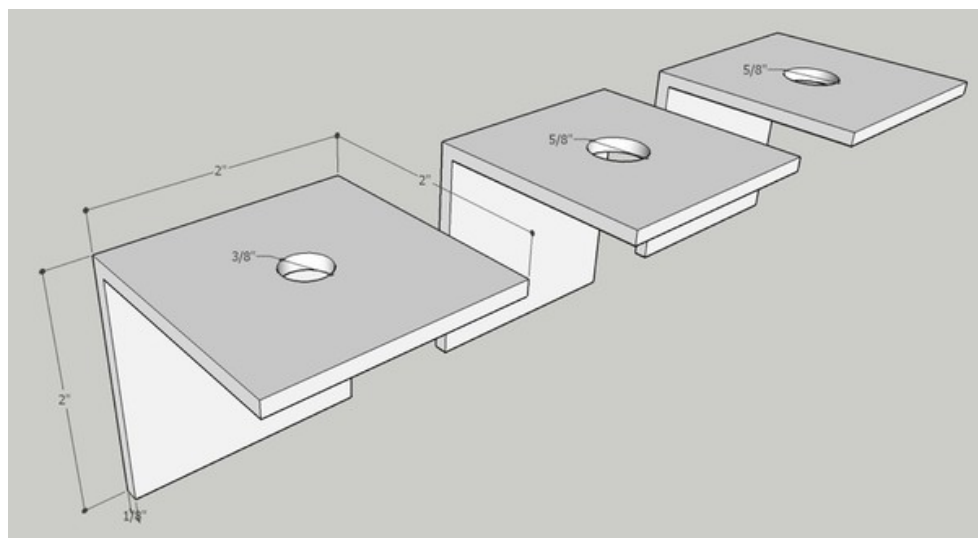

## 6. Electrical cables

- a) The connectors can be purchased from an auto parts store – be aware that they usually require a crimper to attach to the cables. Alternatively, 3/8” copper tubing can be used in 1 1/2” long pieces instead. Strip 1 1/2” insulation from the cable, fully insert fully into 1 1/2” copper tube, flatten end with a hammer and drill hole.



- b) [2] 1 gauge cables: 11” (verify length first!)
- c) 1 gauge cable: 8 1/2” (verify length first!)



## 7. Battery Mounts

- a) [2] 1/4” x 2” x 2” x 4 3/4” Angle
- b) [2] 1/4” x 2” x 5/8” Plate

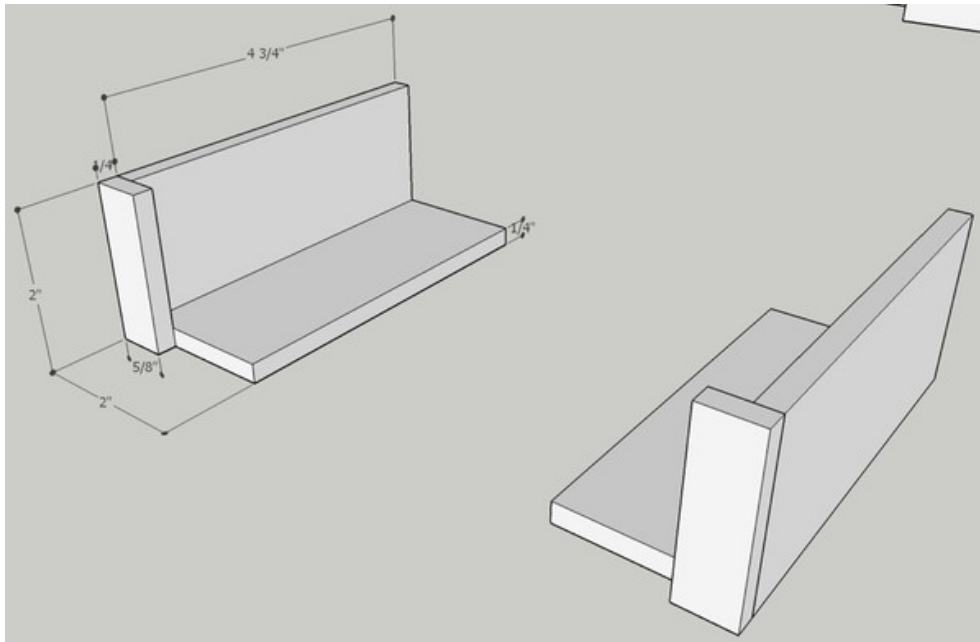

## 8. Oil filter Assembly

a) Assemble as shown, using teflon tape on all threaded components.



b) The parts for this are (from left to right):

- ▲ 1" nipple
- ▲ Oil filter and header
- ▲ 1" to 3/4" reducer
- ▲ 3/4" nipple
- ▲ 3/4" T adapter
- ▲ 3/4" to 3/8" recucer

- ▲ 1/4" quick connect
- ▲ 3/4" T adapter
- ▲ 3/4" quick connect

### 9. Hydraulic reservoir

- a) [2] 1/4" x 6" x 12" Plates
- b) 1/4" x 6" x 12" x 27 1/2" Tube
- c) All welds assembling the reservoir must be quality welds that do not leak. Be careful not to "over weld" the reservoir.
- d) Clean the inside of the tube and the two end plates – anything on these surfaces will end up in the hydraulic oil and could damage the pump or cylinders.
- e) Tack and weld the 6" x 12" plates to both ends of the 6" x 12" tube. Pay attention to the orientation of the plate with the filler hole and the side of the tube with other holes – see the diagram below.

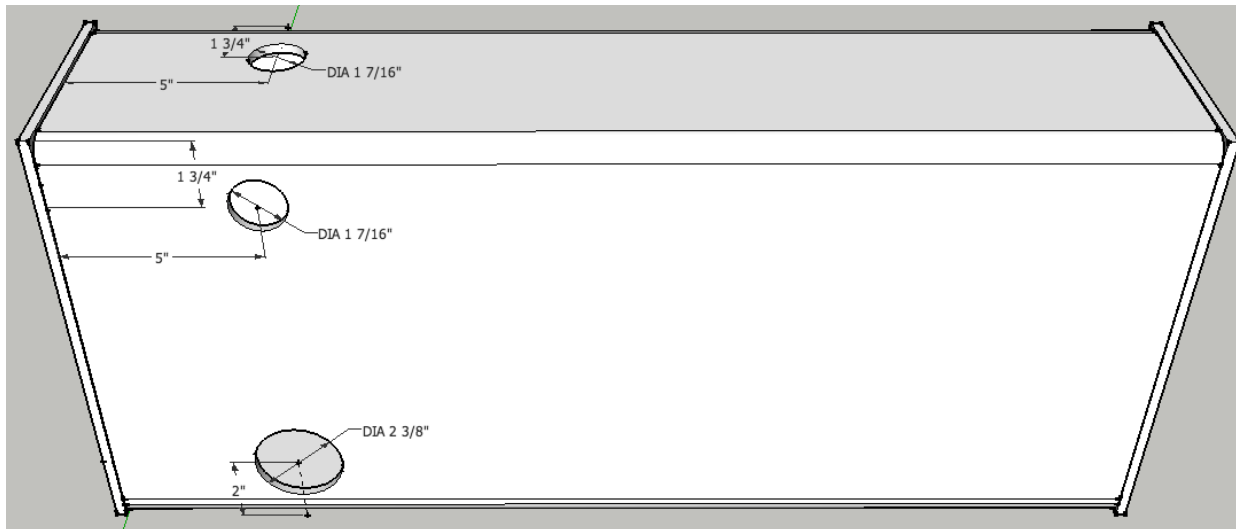

- f) Tack and weld the strainer extension tube to the tank, centered around the strainer hole.
- g) Insert the strainer into the flange and insert it into the strainer extension tube – verify that it slides without binding or bottoming and that the flange is flush with the end of the tube. Remove the strainer from the flange, then tack and weld the flange to the tank.

**CAUTION:** Keep the strainer away from the welding, as its thin wires burn easily.

- h) Install the suction strainer and the hose barb with the hose barb pointing toward the hydraulic pump (Photo below is for assembly, hose barb is oriented differently).

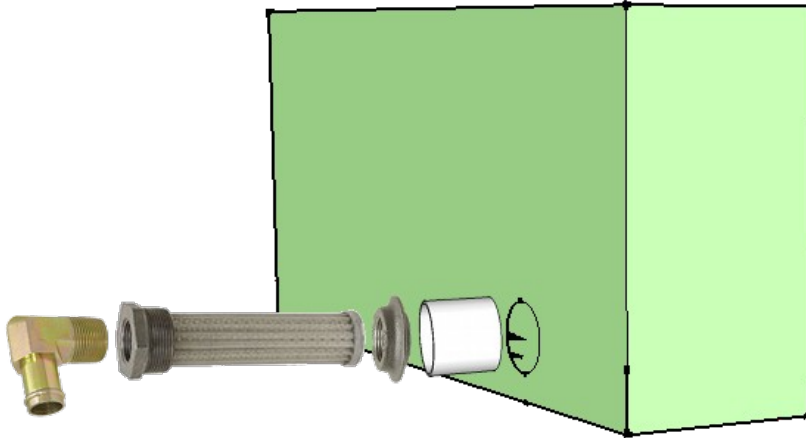

## **Assembly**

Power Cube assembly requires all the parts listed in the Bill Of Materials to be available and prepared as detailed in the “Fabrication” section (above). Assembly requires a welder (electric or torch) capable of welding metal 3/8” thick.

An optional jig can be used to aid in assembly. See Appendix 1 for details.

### 1. Frame

#### a) Top / Bottom Rectangles

Position two 1/4” x 2” x 2” x 29” pieces angle iron on top of two 27” angle pieces as shown below. Check that all joints are square, then tack and weld joints.

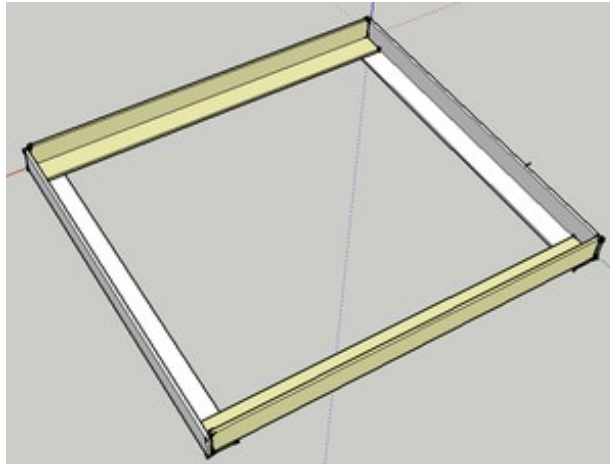

- b) With one welded rectangle on the bottom, position two 24” pieces outside corner joints as shown below. Check that the angles are square, then tack and weld. Note: The optional jig makes this much easier and accurate. Repeat the prior procedure and this one for another half of the frame assembly.



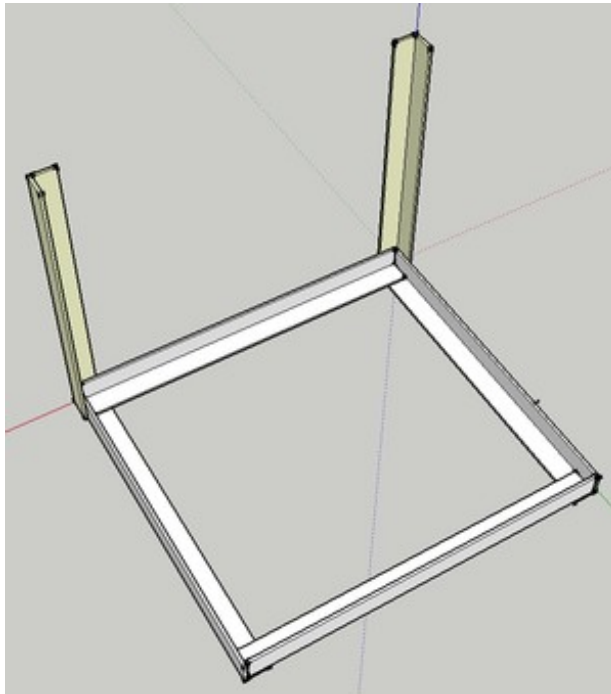

c) Position the second rectangle as shown below, then tack and weld. Inspect all corners to verify secure welds.

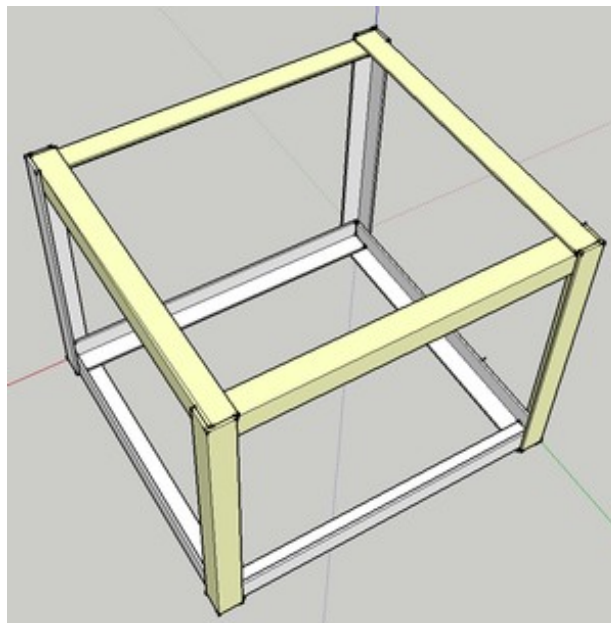

## 2. Gas tank

- a) Screw the 1/4" hose barb into the 1/4 NPT flange welded into the gas tank.
- b) Perform a “soap bubble” test on the tank. Securely cover the larger hole (use something like strong tape), pressurize the tank using the smaller hole and cover the tank surface with soapy water. Look closely for new bubbles, mark any leaks and re-weld securely. Repeat soap bubble test if re-welded.
- c) Tack and weld the gas tank mount (1/4" x 2" x 24" plate) to the frame. Position it so the gas tank is 1" from the nearest vertical angle iron support.
- d) Tack and weld the gas tank to the gas tank mount as shown below.

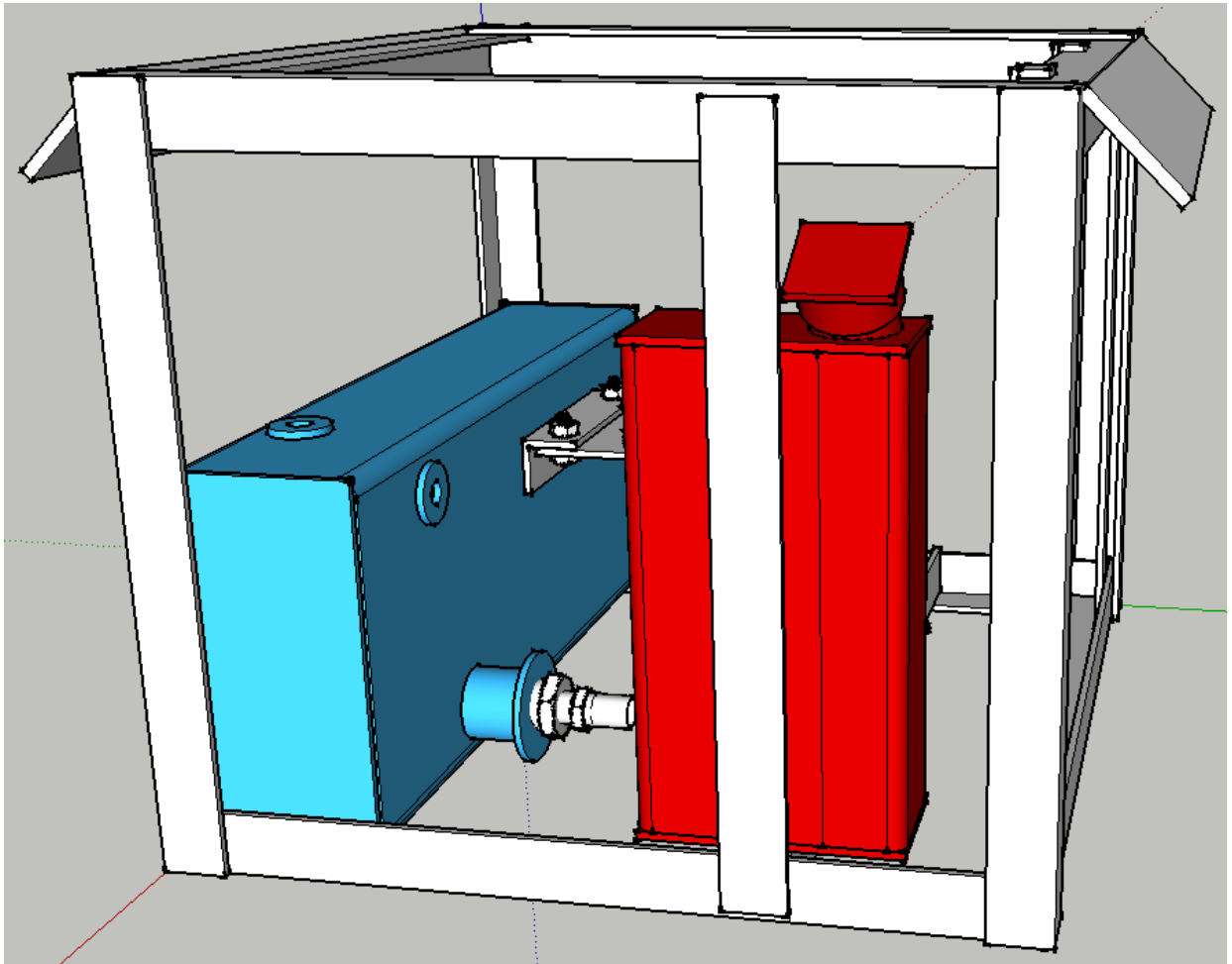

## 3. Hydraulic reservoir

The reservoir should already be pre-assembled and ready for installation.

- a) Perform a “soap bubble” test on the tank by securely covering the larger hole (use something like strong tape), pressurizing the tank using the smaller hole and cover the tank surface with soapy water. Mark any leaks and re-weld securely. Repeat soap bubble test if re-welded.

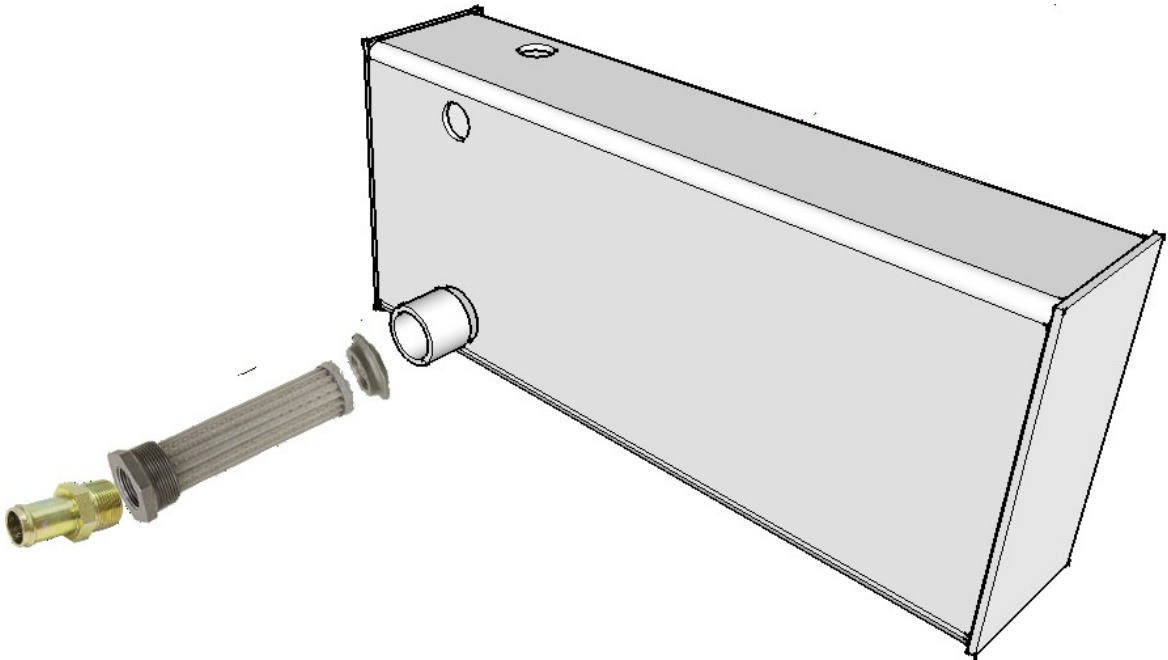

- b) Secure the hydraulic tank to the frame with clamps, then weld it with 4 x 1” welds. The tank is ¼” and it can be easily damaged by over-heating. Spacers may be needed on the sides near the top to keep everything snug.

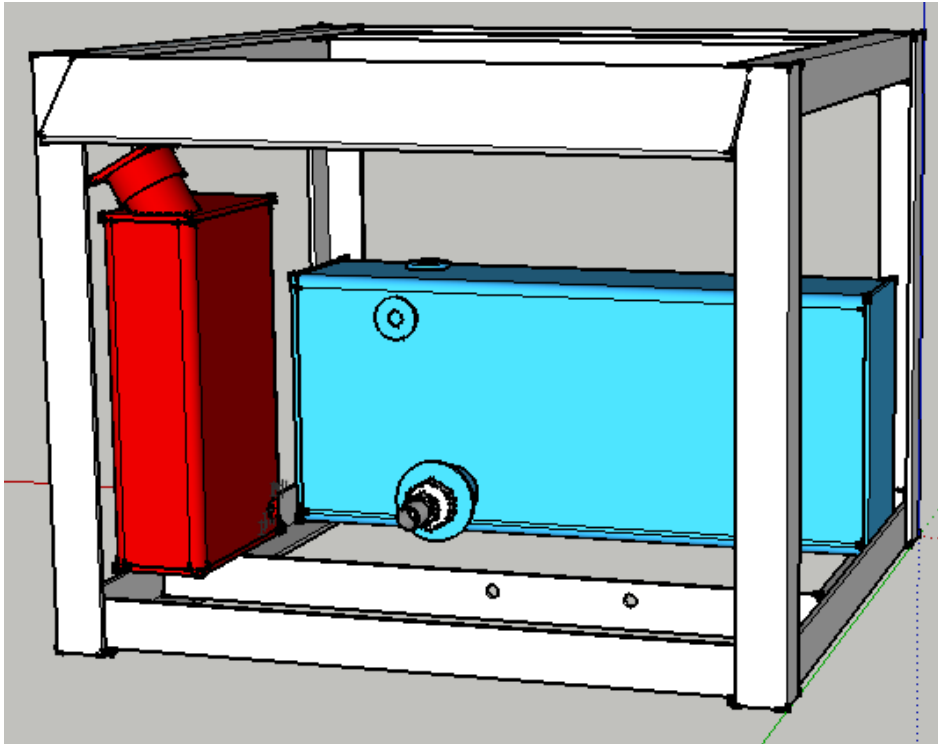

#### 4. Engine Mounts and Hydraulic Pump Mount

- a) Position the  $\frac{1}{4}$ " x 2" x 2" x 29" angle 10  $\frac{1}{4}$ " from the hydraulic tank (see diagram below). Tack and weld it to the frame. Place the  $\frac{1}{4}$ " x 2" x 2" x 8" angle against the tank, 2  $\frac{1}{4}$ " below the tank top and with holes aligned with holes in welded angle. Tack and weld to tank.
- b) Place the  $\frac{1}{4}$ " x 8" x 8" plate on the bottom angle iron, align holes and secure with bolts, nuts and washers.
- c) Place the  $\frac{1}{4}$ " x 8" x 12" plate under the 8" angle, align the holes and secure with two bolts, nuts and washers. Align this assembly with the  $\frac{1}{4}$ " x 8" x 8" plate in the prior step and position the angle against the hydraulic tank, 3" below the tank top as in the diagram below, then tack and weld the two plates together solidly, the full length of the joint.

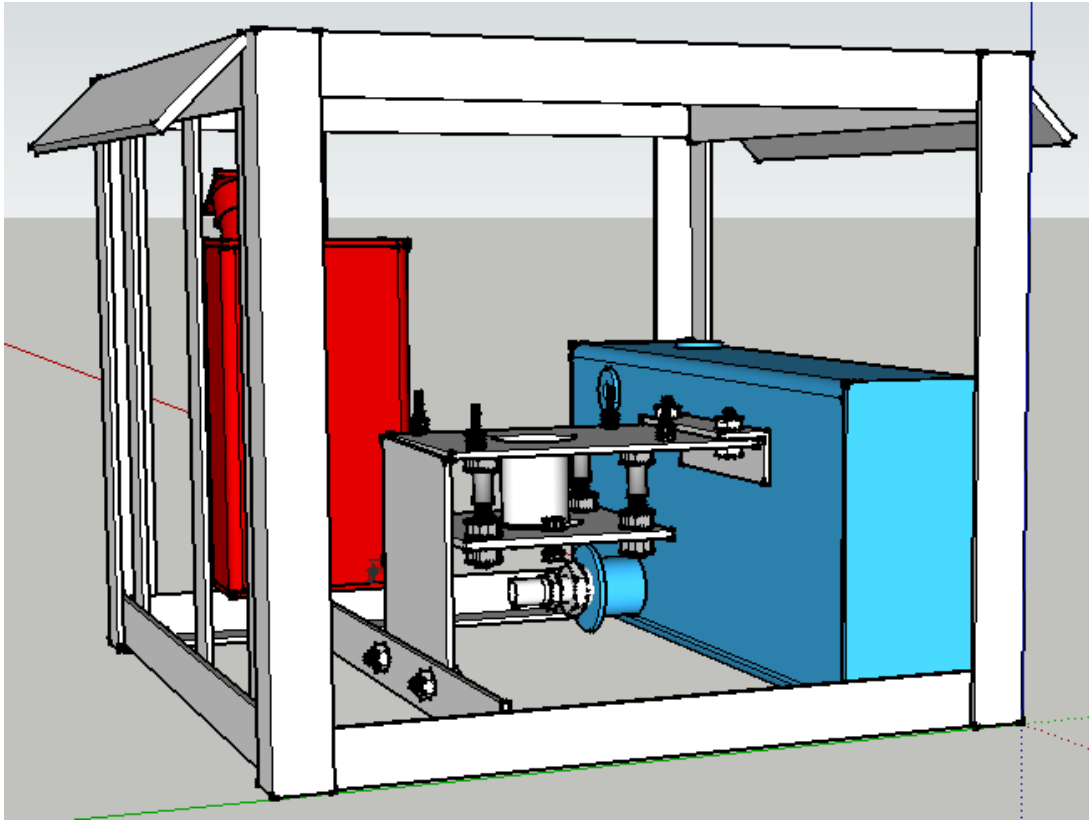

- d) Place the  $\frac{1}{4}$ " x 8" x 8" plate on the bottom angle iron, align holes and secure with bolts, nuts and washers.
- e) Place the  $\frac{1}{4}$ " x 8" x 12" plate under the 8" angle, align the holes and secure with two bolts, nuts and washers. Align this assembly with the  $\frac{1}{4}$ " x 8" x 8" plate in the prior step and position the angle against the hydraulic tank, 3" below the tank top as in the diagram below, then tack and weld the two plates together.
- f) Tack and weld the corner formed by the two 8" plates.
- g) Examine the engine shaft – it should be 2" long. If longer, cut the shaft to extend no more than 2" from the case. This length is necessary for the coupling.
- h) Hoist the engine and lower it on the mounting plate, centering it on the plate. Verify the engine mounting holes are evenly spaced on each side of the plate and the shaft extends through the hole without touching.

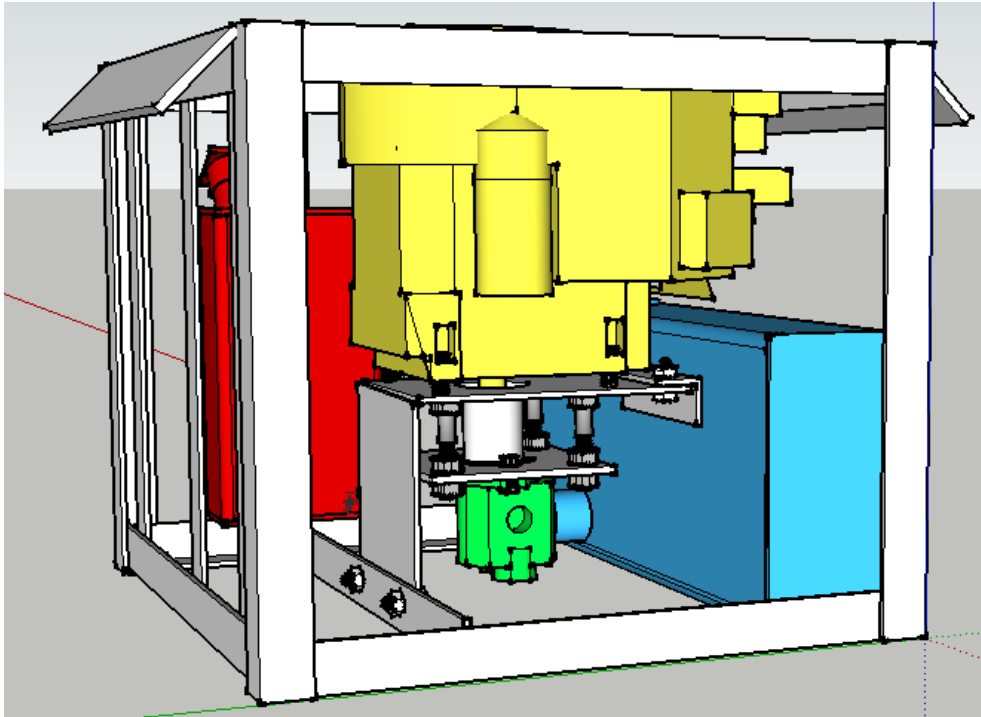

- i) Thread the  $\frac{1}{4}$ " x 2" engine mounting bolts each about half-way with nuts, then lift each side of the motor and insert the bolts into the engine mounting holes. Adjust the nuts so the space between the plate and the engine is  $\frac{1}{2}$ " and the engine rests evenly on all four bolts. Lightly weld the bolts in place to the plate.



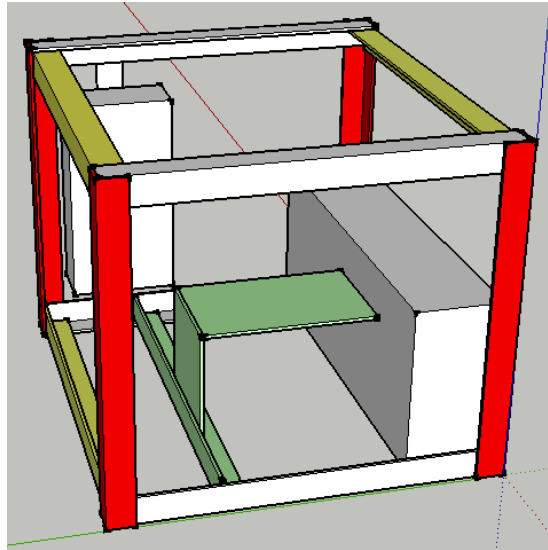

#### 5. Battery mount

- a) Weld the  $\frac{1}{4}$ " x 2" x  $\frac{5}{8}$ " plates to the ends of the  $\frac{1}{4}$ " x 2" x 2" x 4  $\frac{3}{4}$ " plates as shown below.

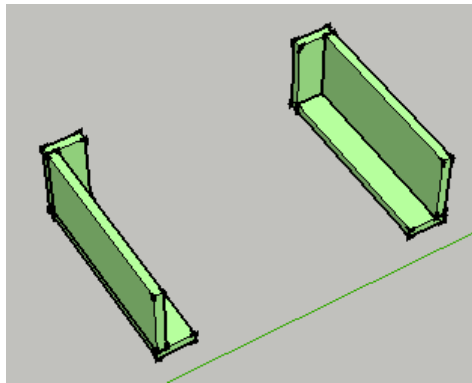

- b) Weld the two mounts to the angle iron and tank to form a rectangle for the battery as shown below.

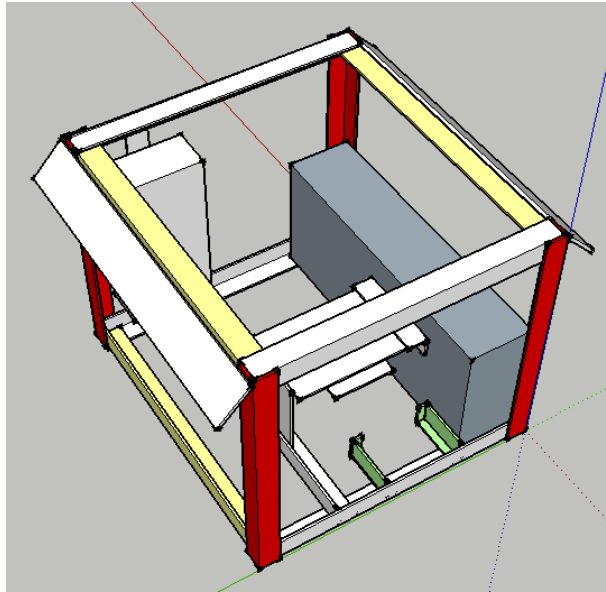

c) After the mount has cooled, lower the battery into the rectangle to verify a proper fit.

#### 6. Oil cooler and fan mounts

a) Position the two  $\frac{1}{4}$ " x 2" x 22" plates to the outside of the frame, adjust so the oil cooler mounting bolts match the holes in the plates and is positioned as in the diagram below. Tack and weld the mounts in to the frame. Verify that the oil cooler bolts match the holes in the mounts.

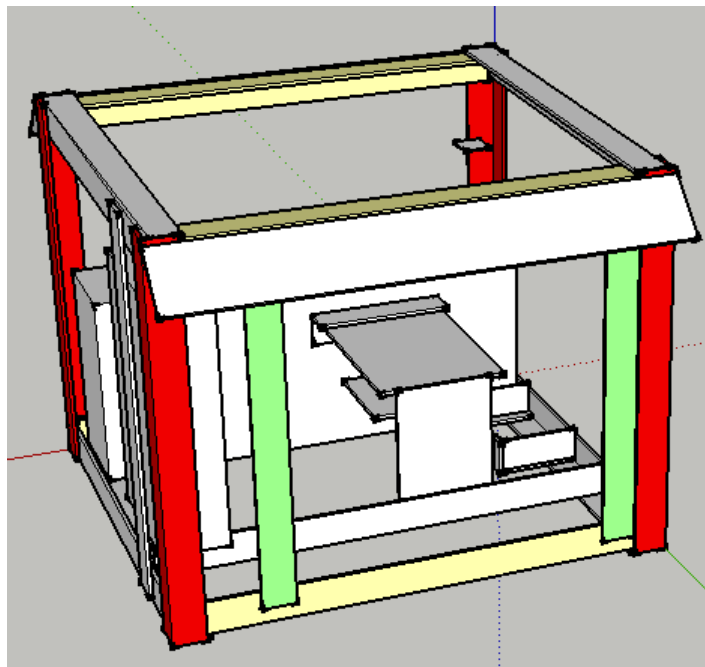

b) Use the mounting holes in the fan shroud and the oil cooler width for positioning the



mounting plates as shown in the diagram below. Position the four  $\frac{1}{4}$ " x 2" x 1" plates, then tack and weld. Position the two  $\frac{1}{4}$ " x 2" x 24" plates against the 1" plates, then tack and weld. Place the fan on the supports and mark the mounts with bolt hole positions. Place the bolt heads against the fan mounting plate and weld in place. Verify that the bolts match the holes in the fan. Inside the frame, adjust the fan position to position fan shroud  $\frac{1}{4}$ " from oil cooler fins. Be careful with radiator as the delicate fins are easily bent and damaged.

- c) Place the 9 gauge x 12" x 22" expanded steel grill in front of the oil cooler mounting plates, positioned to cover the entire oil cooler and check if any holes are necessary to secure with oil cooler mounting bolts.

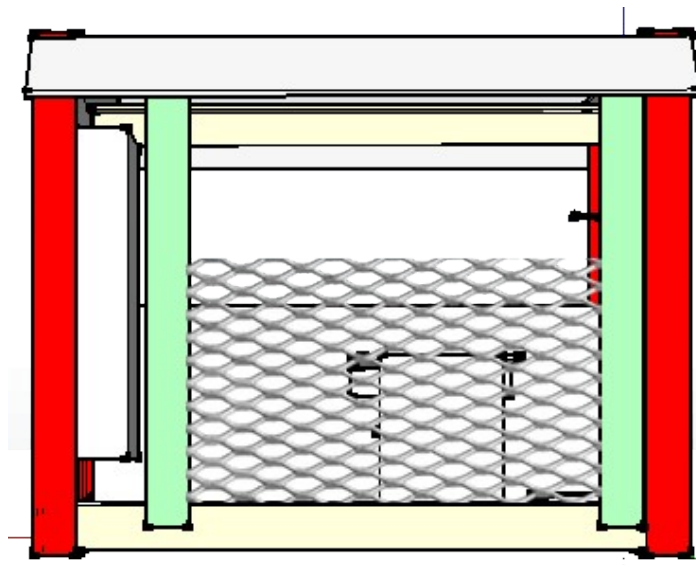

7. Screw the filter assembly into the flange on the side of the hydraulic reservoir.



8. Connect the 1" suction hose between the strainer and the pump intake.
9. Connect a male  $\frac{3}{4}$ " quick connect hydraulic coupler to the pump output.
10. Connect a female  $\frac{3}{4}$ " to  $\frac{3}{4}$ " elbow to the cooler port nearest the battery cage.
11. Connect one end of the  $\frac{3}{4}$ " x 1' hydraulic hose to the second cooler port, then connect the other end of the  $\frac{3}{4}$ " x 1' hydraulic hose to filter assembly.

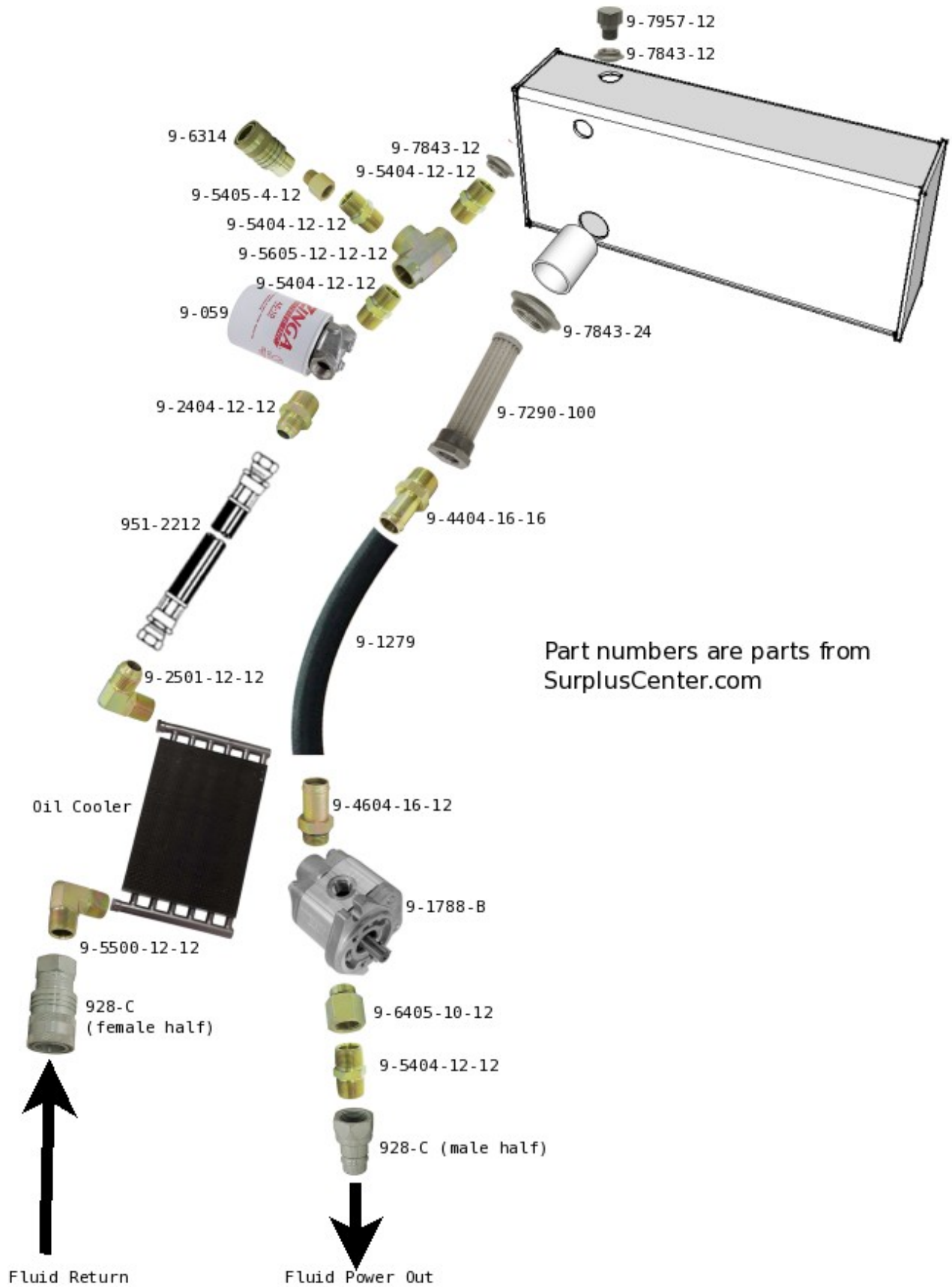

12. Weld the 1/8" x 2" x 2" x 2" angle brackets to the frame in the positions shown below. Pay special attention to the hole sizes, as the bracket for the choke has a smaller hole.

<image>

13. Weld the solenoid mounting bolts to the hydraulic reservoir as shown below.

<image>

14. Wire the switches.

15. Fix the throttle control, connect to throttle plate.

## ***User Guide***

This section is intended for the end user of the Power Cube.

1. Caution
  - a) Weight
  - b) Hydraulic hazards
  - c) Ventilation
2. Mounting
  - a) Quick attach connector
3. Initial startup and testing
  - a) Initial Setup
    - ▲ Gasoline
    - ▲ Hydraulic Fluid
    - ▲ Battery Connection
  - b) Startup
  - c) Hydraulic Test
4. Routine use
5. Maintenance
  - a) Engine Oil
  - b) Hydraulic Fluid
6. Troubleshooting
  - a) Engine won't start
  - b) Loud noise
  - c) No hydraulic power

## Appendix

### Frame Assembly Jig

The welding “jig” in the image below is helpful to insure square angles while assembling the Power Cube. It is very useful if building multiple Power Cubes.

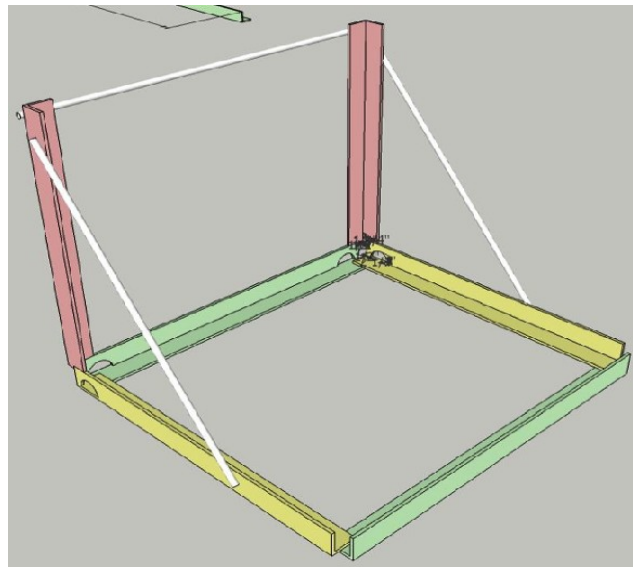

Note the corner holes that provide access for welding:

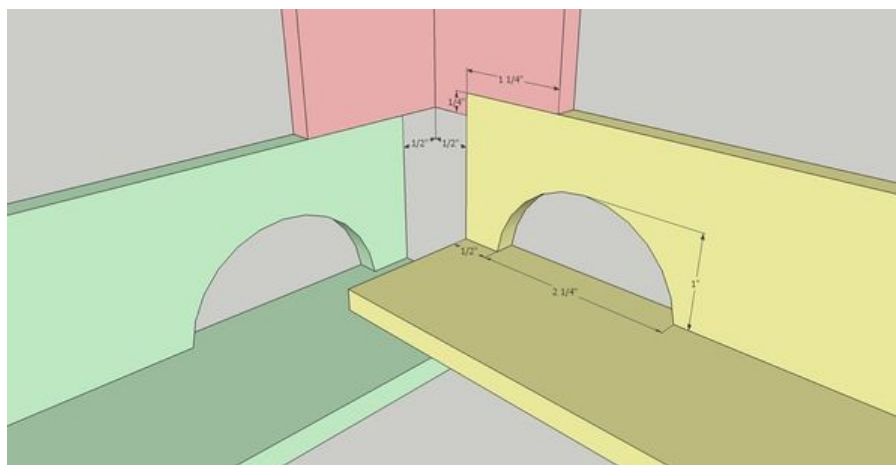

### Materials List

- 1/4" x 2" x 2" Angle Iron: 14'

- ½" Rebar: 7' 2"

**Cut List**

Type	Length	Dimensions	Quantity	Color
Angle	22"	¼" x 2 x 2"	2	(red)
Angle	26"	¼" x 2" x 2"	2	(yellow)
Angle	29"	¼" x 2" x 2"	2	(green)
Rebar	30.5"	½"	1	
Rebar	27"	½"	2	