

Workshop:

Micro Power Cube (μ PC)

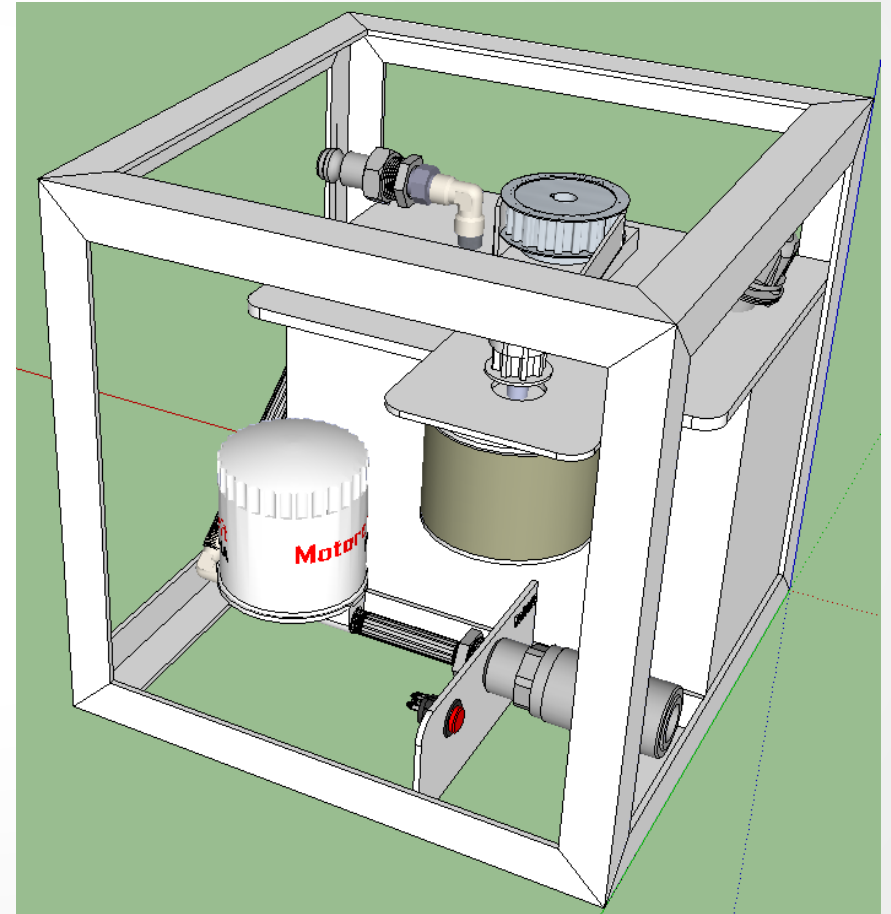

μPC Summary

- Dimensions: 1 cubic foot
- Weight: 24 lbs (dry)
- Power: 1.9 HP (peak) from 120V AC
- Connections: ¾" Quick Coupler

Components

- Frame
- Motor support bracket
- Output bracket
- Hydraulic power unit
- Oil filter
- Electric motor

Hydraulic Assembly

- Connect hydraulic fittings (outside frame)
- Use teflon tape to seal all NPT threads from leaks
- Let output plate hang loosely for now

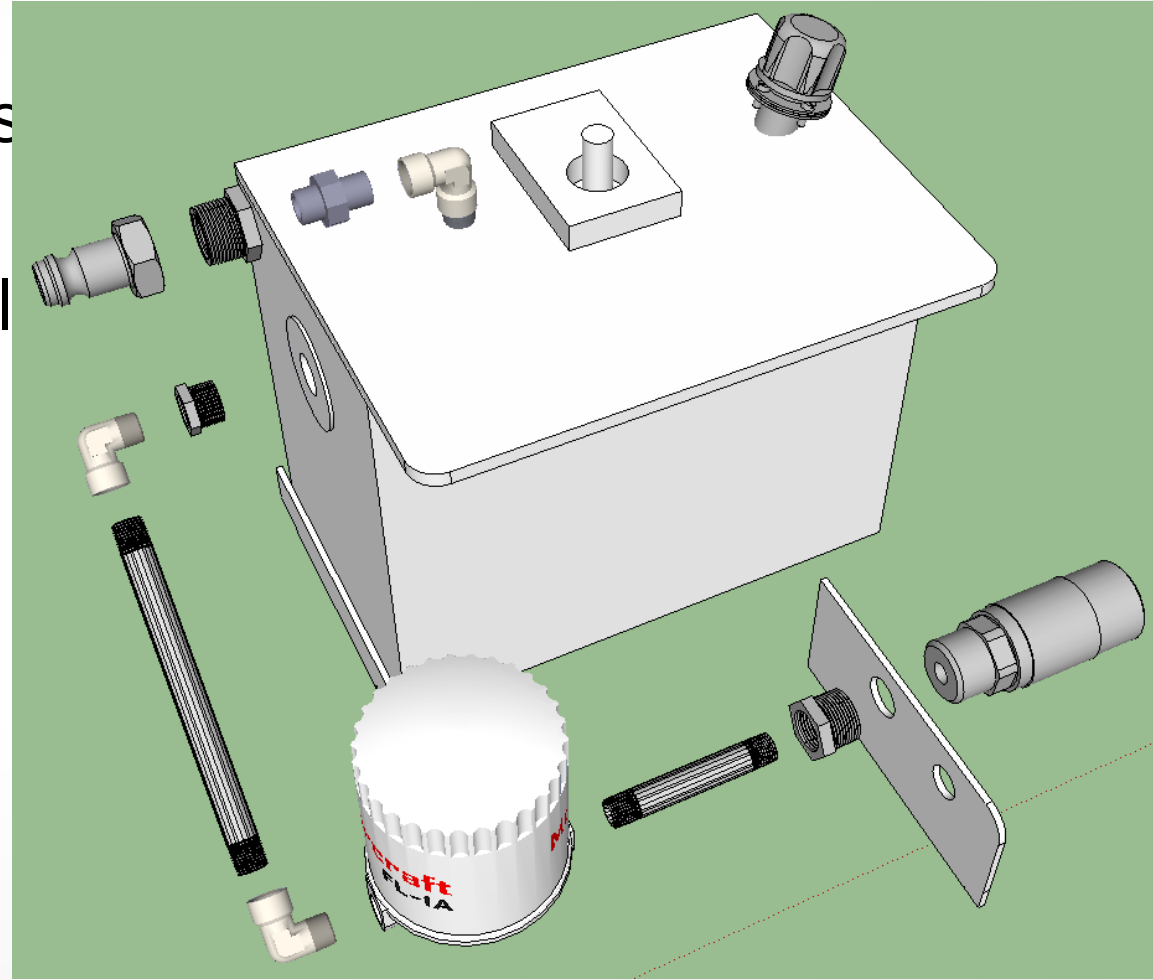

Cutting Steel

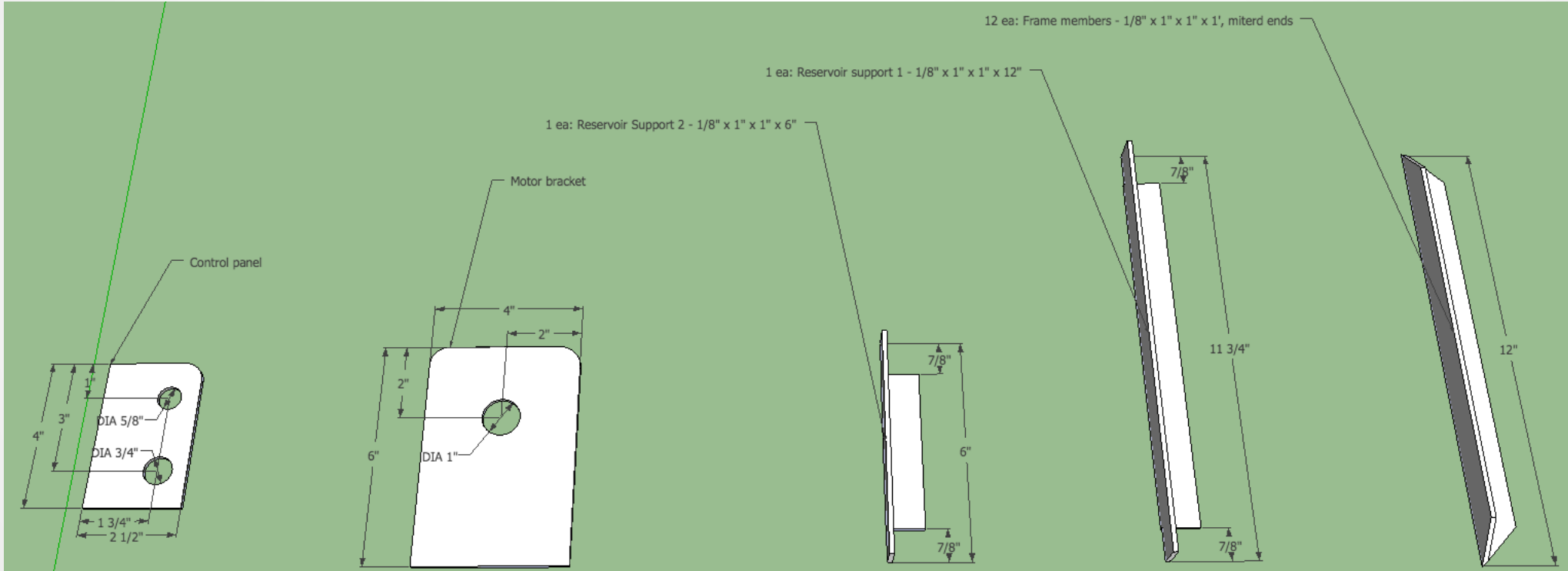

Frame Fabrication

- Grind frame member ends
- Align and weld “V”s
- Align and weld squares from “V”s
- Align and weld “spars” to squares
- Join frame together
- Weld reservoir brackets
- Drill hole, prepare clamp

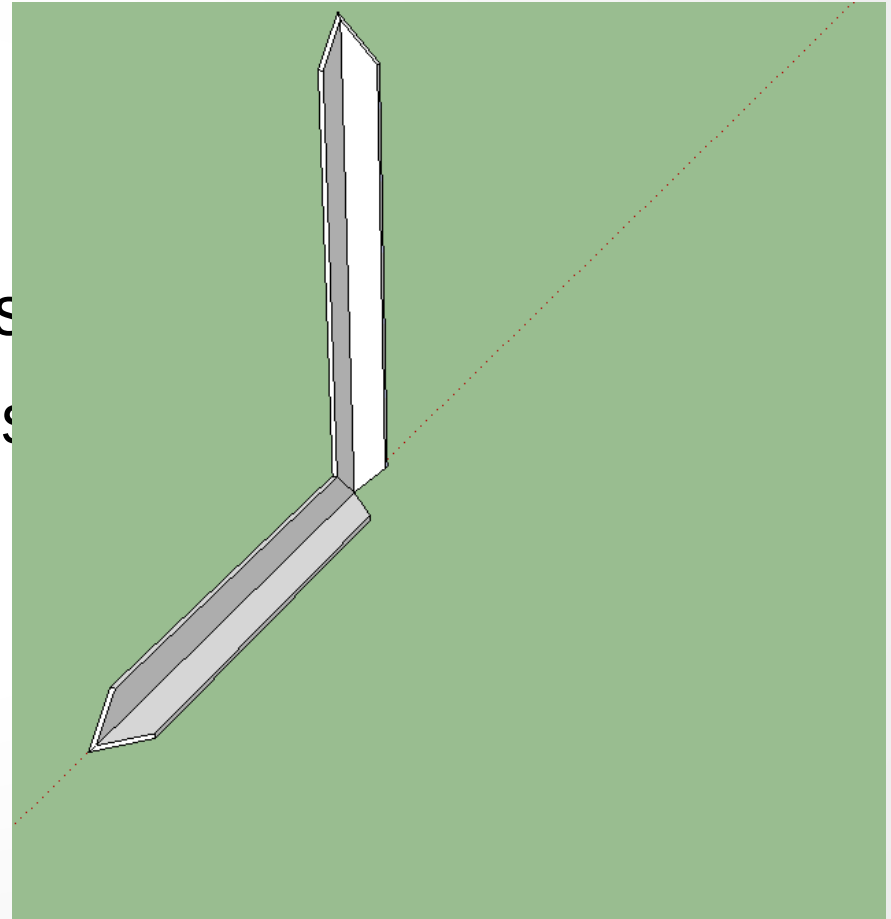

Reservoir Clamp

- 1/8" x 1" x 1" x 3/4" Angle Iron
- Flat screw and hex bolt - 1/4"

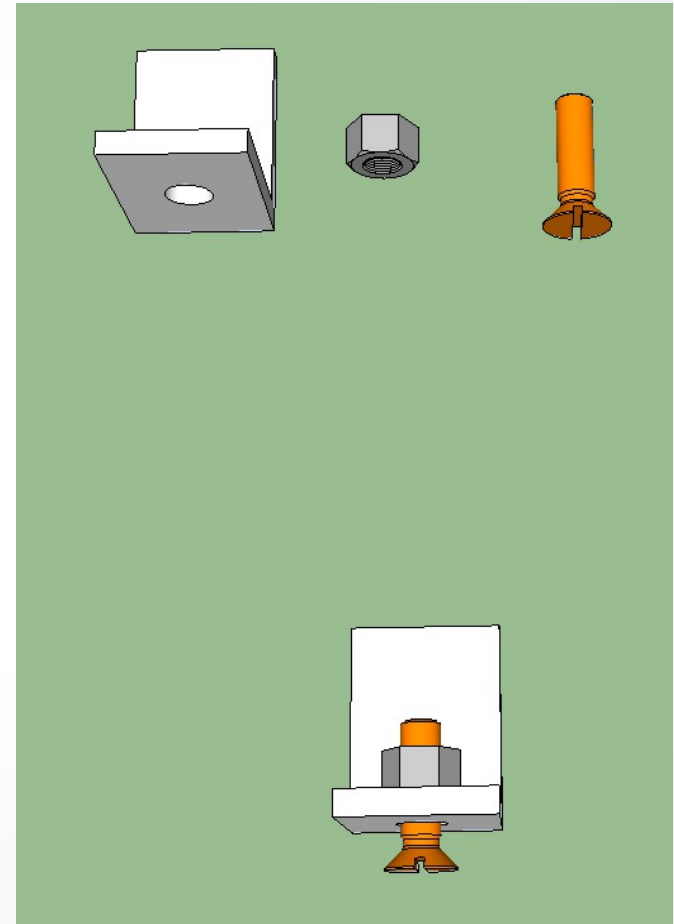

Motor Support

- Drill the motor support for motor mounting holes
- Mount motor on support
- Drill / bore hole in small gearpulley per motor shaft
- Drill hole in small gearpulley for set screw
- Drill hole in large gearpulley for set screw
- Secure all parts

Modify Power Unit

- Remove “extra” overhang from hydraulic power unit
- Drill / cut / file remaining overhang for mounting motor and to allow motor to slide and tension belt
- Test motor mounting, adjust as necessary

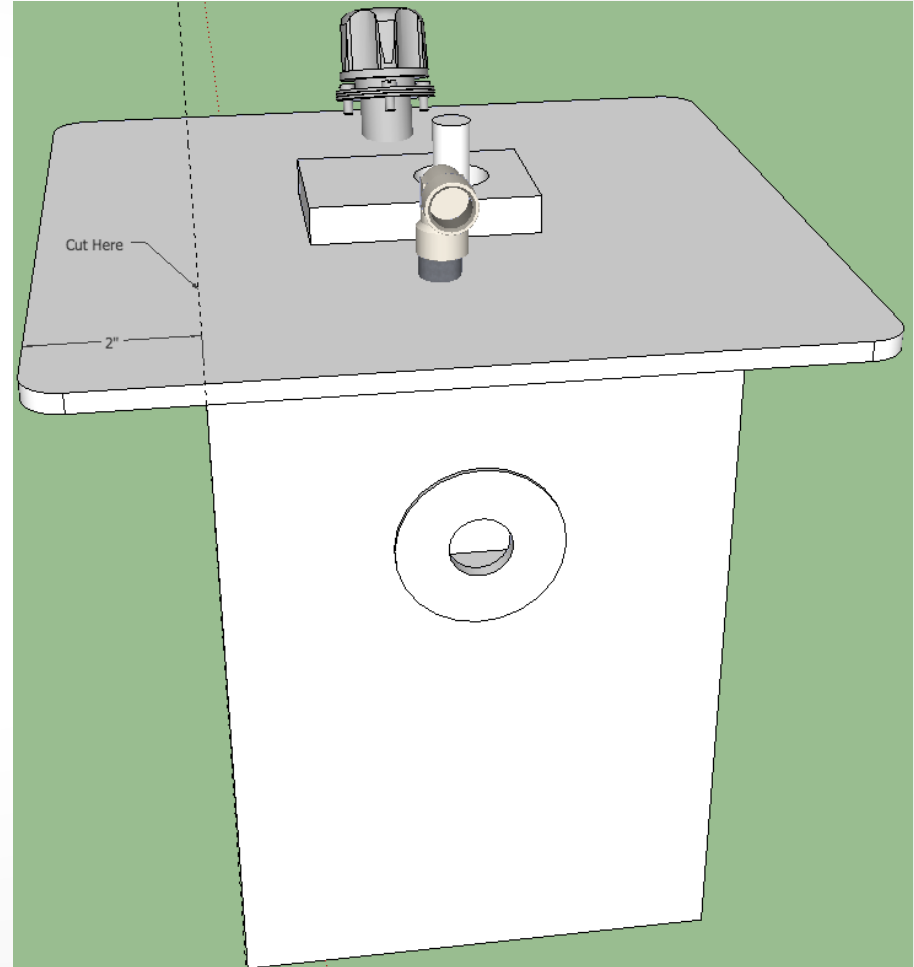

Prepare Pulleys

- Bore motor pulley for tight fit on motor shaft
- **Precision note** Hole must be centered in pulley and be along pulley axis – this prevents “wobble” in pulley and belt

Final Assembly

- Install reservoir into frame, secure with clamp
- Weld output plate to frame
- Remove reservoir and paint frame
- Install reservoir, attach motor to reservoir
- Attach pulleys and belt
- Tension belt
- Connect switch and power cord

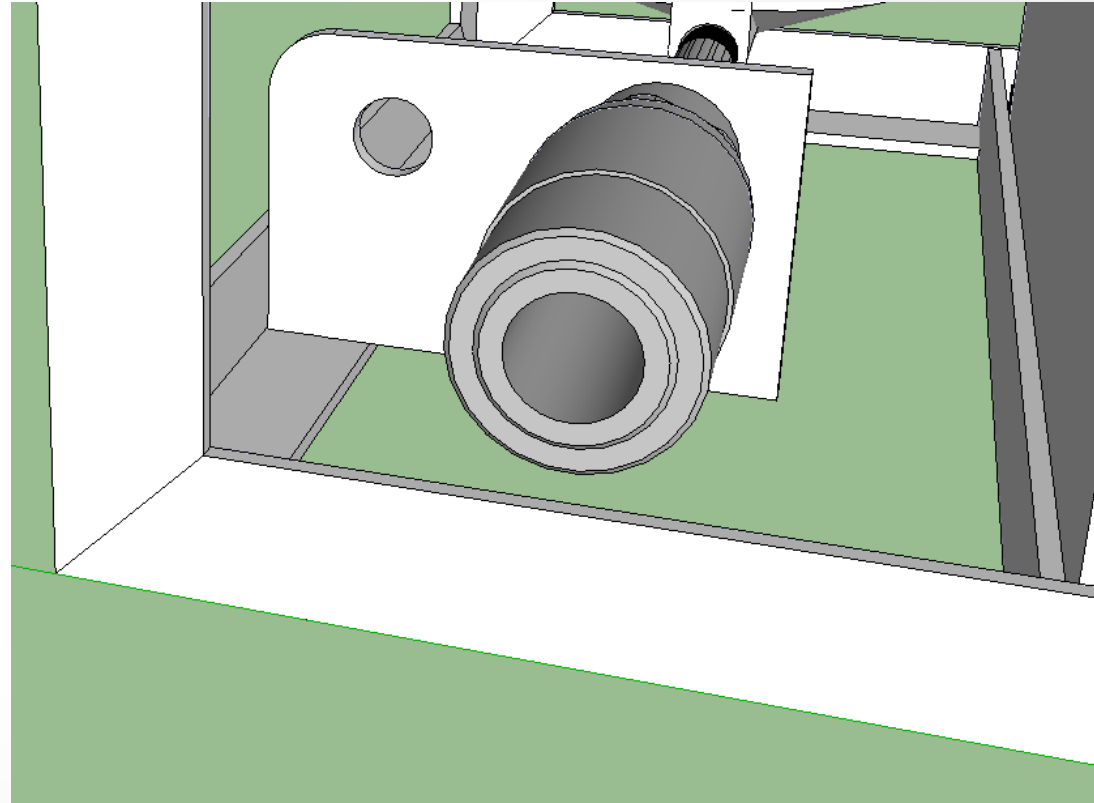

Micro Power Cube Complete

- Ready to test!

