

Item Number	Quantity	Part Name	Comment	Description
192	2	01-192-00-3 L-F13		L-F13
193	1	01-193-00-3		MCMASTER 8739K74 - WEAR RESISTANT ACETAL
194	1	01-194-00-3 L-F14		L-F14
195	2	01-195-00-3 L-F15		L-F15
196	1	01-196-00-3 L-F16		L-F16
199	1	01-199-00-0		(14GA APROX.) SHEET METAL BACKING FOR PLASTIC BLOCK
211	1	211 - hex nut_ai_HNUT 0.7500-10-D-C	3/4 HN	3/4 HEX NUT
218	2	218 - .375 HEX NUT		218 - 3/8 HEX NUT
219	2	219 - .375 X 1.5 SHCS		3/8-16 SHCS X 1-1/2

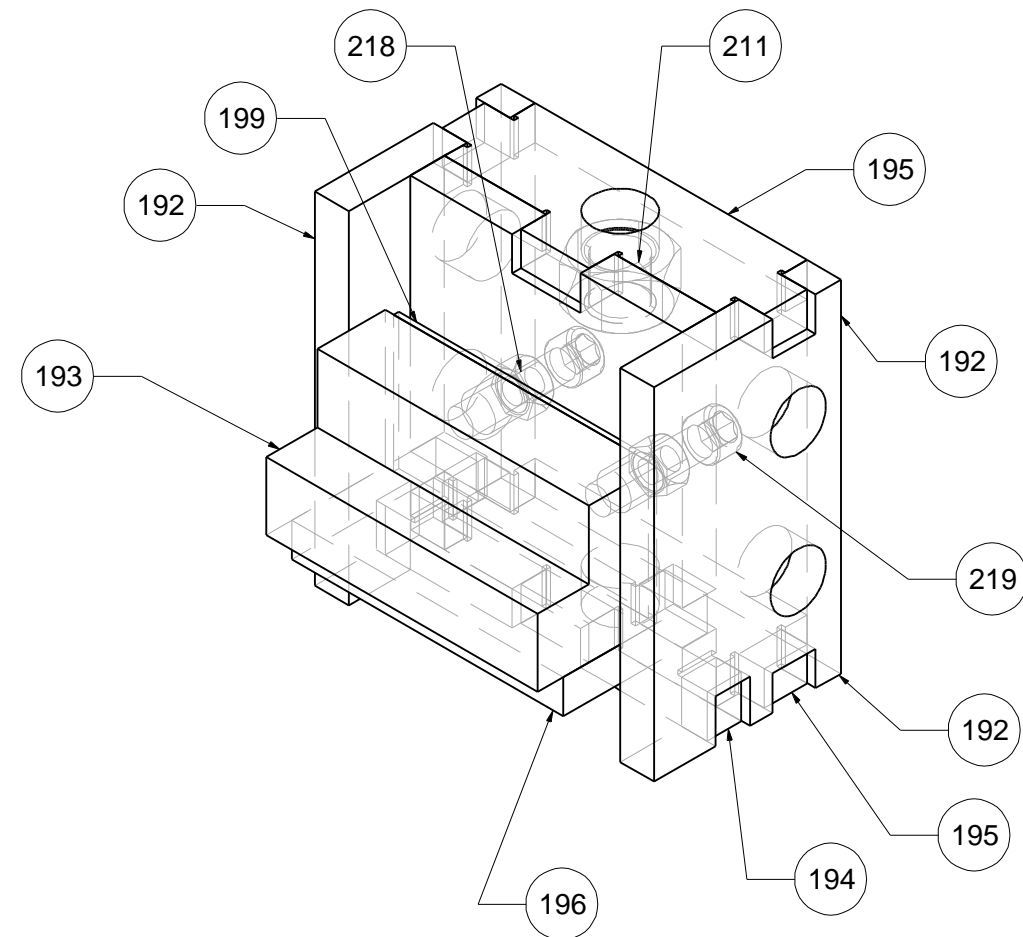

PLEASE PROCEED AT YOUR OWN RISK!
 THESE DRAWINGS ARE MEANT TO DOCUMENT
 PREVIOUS WORK AND PRESENT IDEAS ONLY;
 THEY ARE NOT MEANT TO BE A COMPLETE GUIDE.
 WORKING WITH ANY TOOLS, EQUIPMENT,
 HYDRAULICS, ELECTRONICS, ETC. MAY
 CAUSE SERIOUS INJURY OR DEATH.

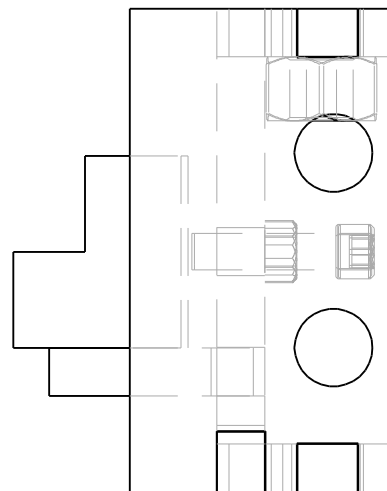
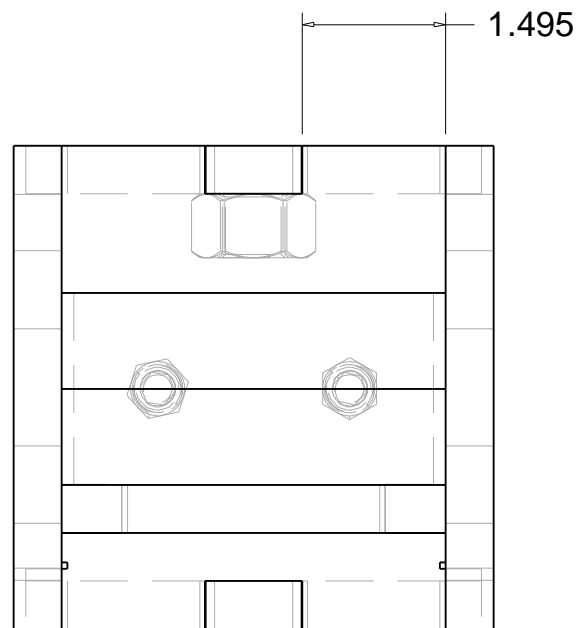
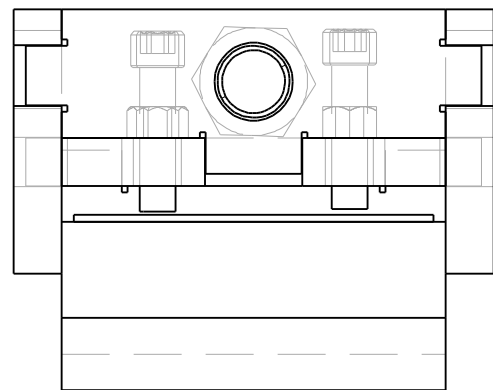
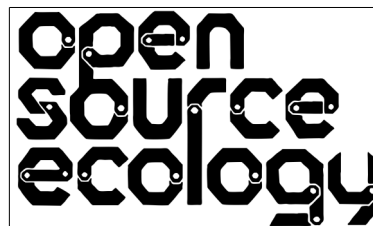

LICENSE INFORMATION
 ALL INFORMATION IS RELEASED UNDER THE OSE
 LICENSE FOR DISTRIBUTIVE ECONOMICS. FOR
 FURTHER INFORMATION GO TO:
 OPENSOURCEECOLOGY.ORG/WIKI/LICENSE

	NAME	DATE	PROJECT:	
DRAWN	RHB		CEB PRESS 5	
CHECKED			DESCRIPTION:	
APPR.			UNLESS OTHERWISE SPECIFIED DIMENSIONS ARE IN INCHES	
ANGLES	.X	.XX	.XXX	
	+-.5	+-.1	+-.03	+-.005
THIRD ANGLE PROJECTION				

SIZE	DWG. NO.	REV
B	01-149-00-3	
SCALE: NONE	WEIGHT:	

8 7 6 5 4 3 2 1

D
C
B
A

D
C
B
A

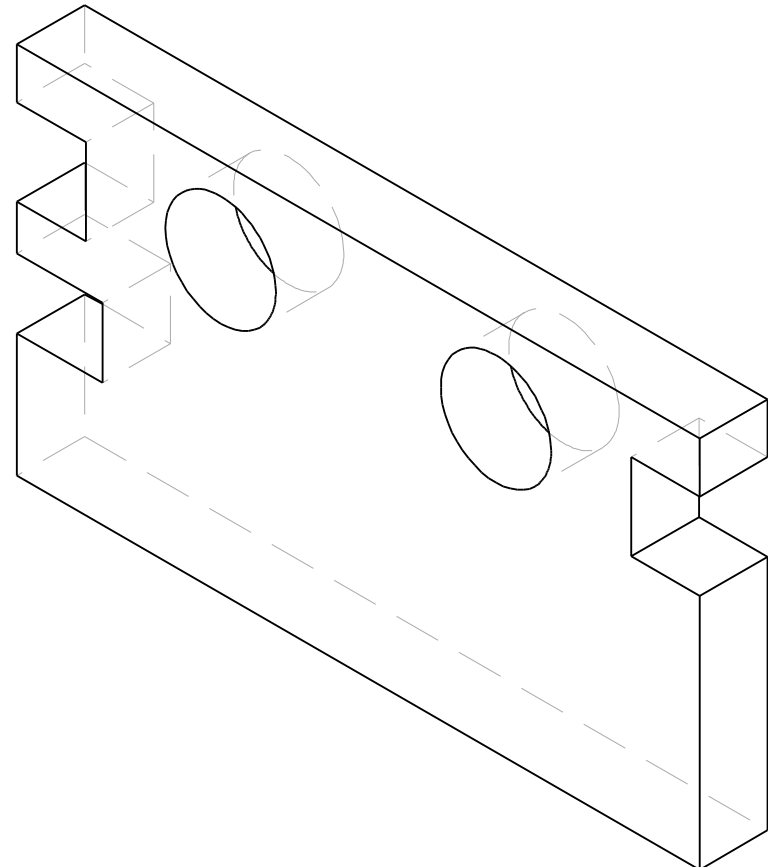
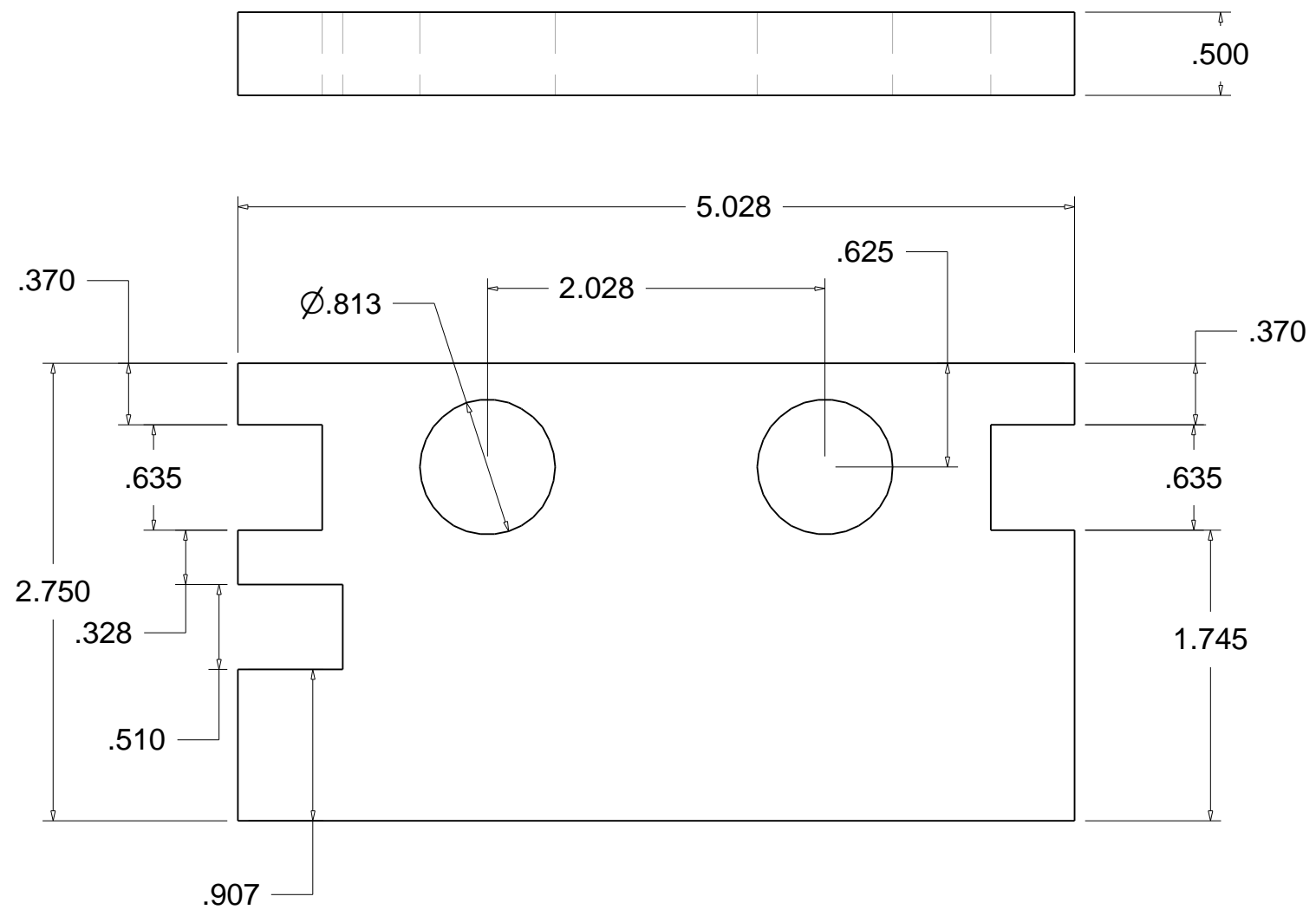

PLEASE PROCEED AT YOUR OWN RISK!
 THESE DRAWINGS ARE MEANT TO DOCUMENT
 PREVIOUS WORK AND PRESENT IDEAS ONLY;
 THEY ARE NOT MEANT TO BE A COMPLETE GUIDE.
 WORKING WITH ANY TOOLS, EQUIPMENT,
 HYDRAULICS, ELECTRONICS, ETC. MAY
 CAUSE SERIOUS INJURY OR DEATH.

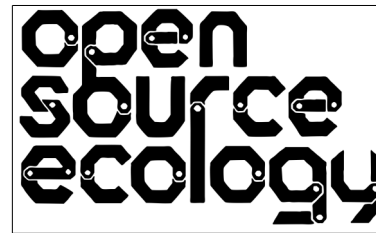

LICENSE INFORMATION
 ALL INFORMATION IS RELEASED UNDER THE OSE
 LICENSE FOR DISTRIBUTIVE ECONOMICS. FOR
 FURTHER INFORMATION GO TO:
 OPENSOURCEECOLOGY.ORG/WIKI/LICENSE

	NAME	DATE	PROJECT:	
DRAWN	RHB		CEB PRESS 5	
CHECKED			DESCRIPTION:	
APPR.			L-F13	
UNLESS OTHERWISE SPECIFIED DIMENSIONS ARE IN INCHES				
ANGLES	.X	.XX	.XXX	
+-.5	+-.1	+-.03	+-.005	

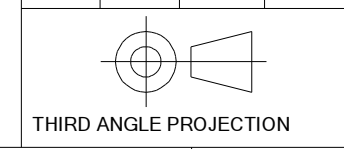

SIZE	DWG. NO.	REV
B	01-192-00-3 L-F13	
SCALE: NONE	WEIGHT:	

8 7 6 5 4 3 2 1

8 7 6 5 4 3 2 1

D

D

C

C

B

B

A

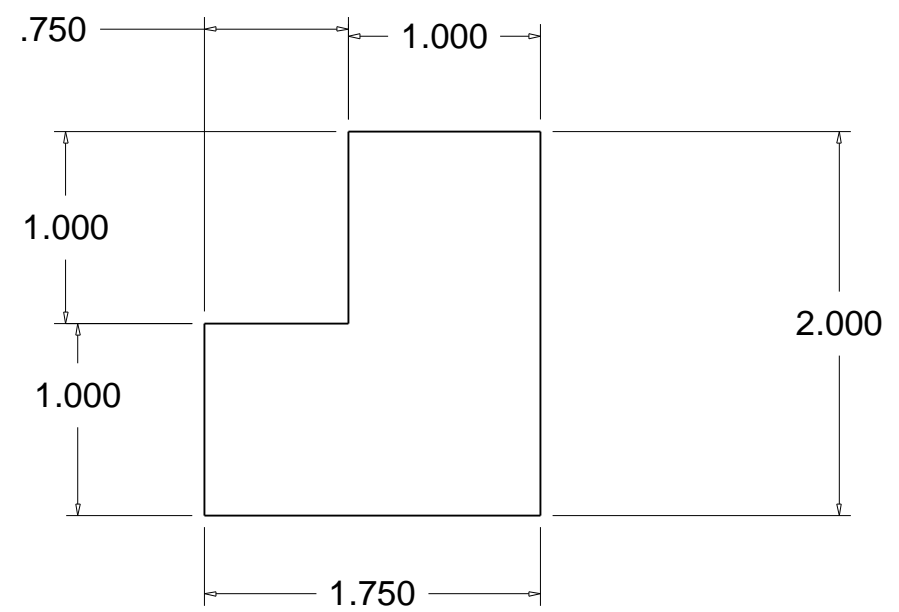
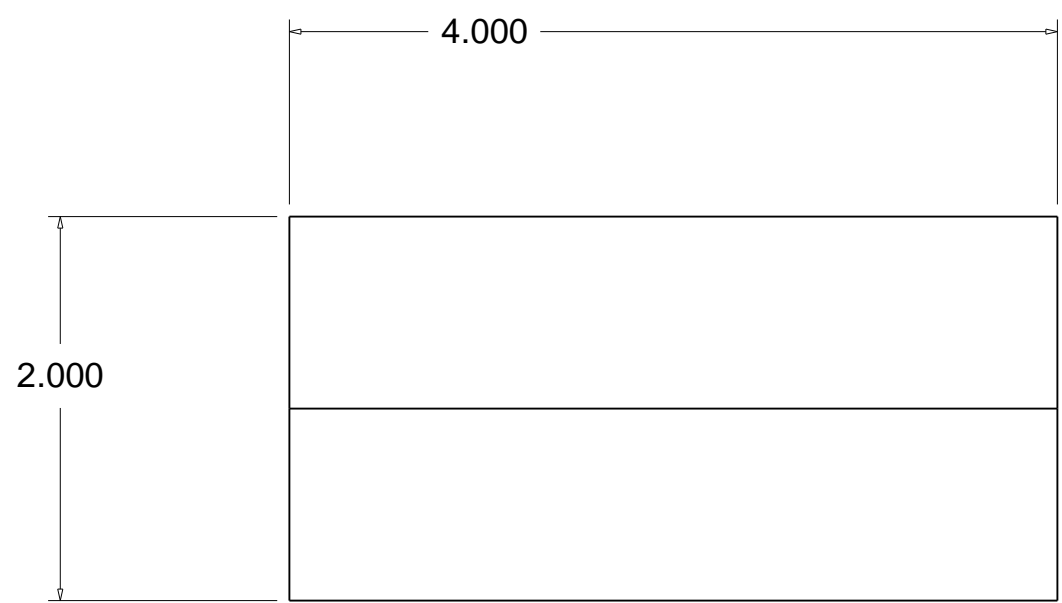
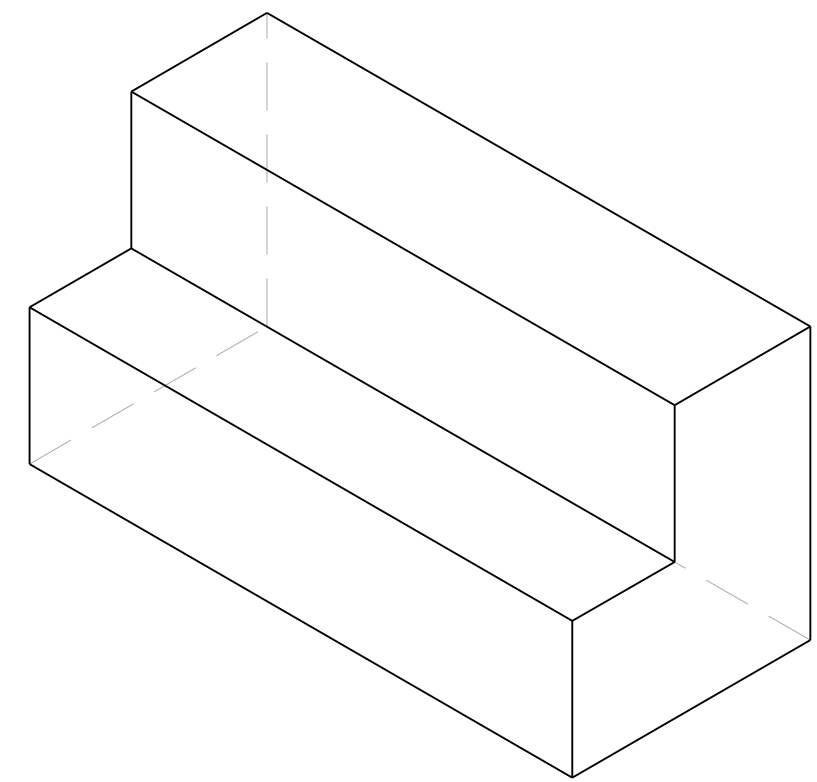

PLEASE PROCEED AT YOUR OWN RISK!
 THESE DRAWINGS ARE MEANT TO DOCUMENT
 PREVIOUS WORK AND PRESENT IDEAS ONLY;
 THEY ARE NOT MEANT TO BE A COMPLETE GUIDE.
 WORKING WITH ANY TOOLS, EQUIPMENT,
 HYDRAULICS, ELECTRONICS, ETC. MAY
 CAUSE SERIOUS INJURY OR DEATH.

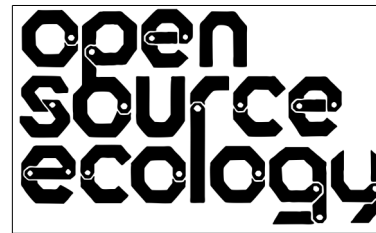

LICENSE INFORMATION
 ALL INFORMATION IS RELEASED UNDER THE OSE
 LICENSE FOR DISTRIBUTIVE ECONOMICS. FOR
 FURTHER INFORMATION GO TO:
 OPENSOURCEECOLOGY.ORG/WIKI/LICENSE

	NAME	DATE
DRAWN	RHB	
CHECKED		
APPR.		
UNLESS OTHERWISE SPECIFIED DIMENSIONS ARE IN INCHES		
ANGLES	.X	.XX
	+-.5	+-.1
		+-.03
		+-.005

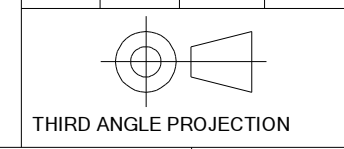

PROJECT: **CEB PRESS 5**

DESCRIPTION:
MCMASTER 8739K74 - WEAR RESISTANT ACETA

SIZE DWG. NO. REV

B 01-193-00-3

SCALE: NONE WEIGHT:

8 7 6 5 4 3 2 1

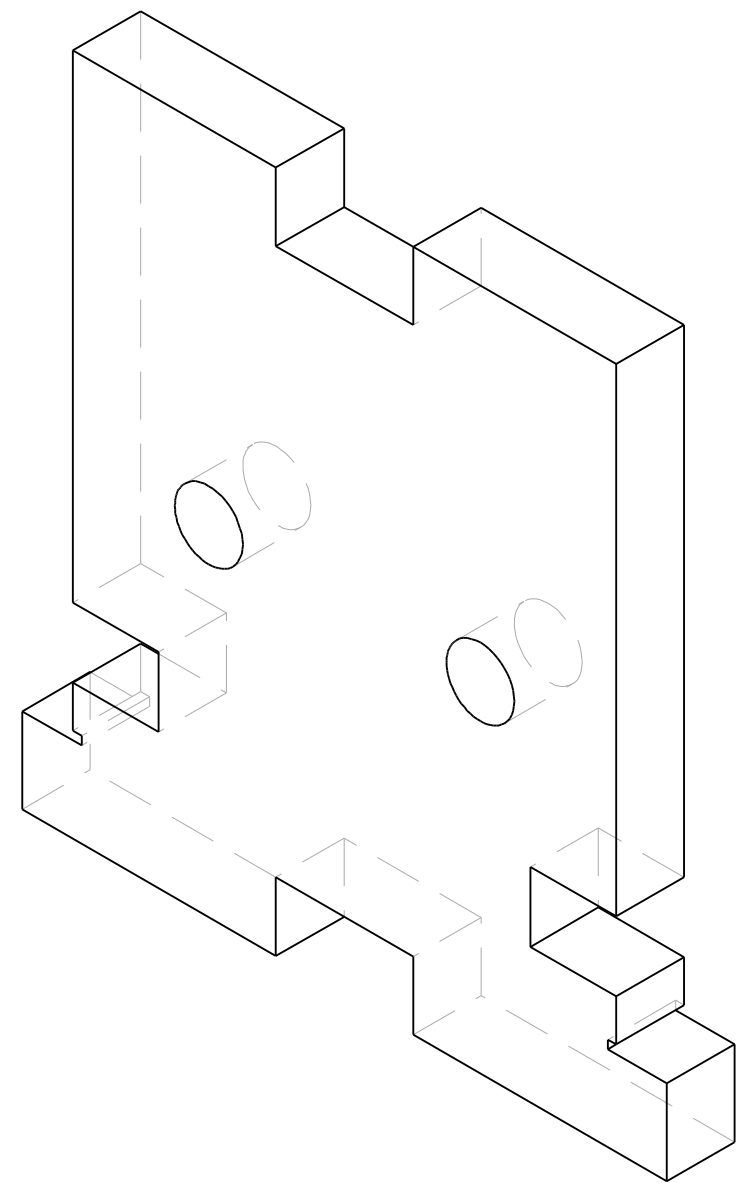
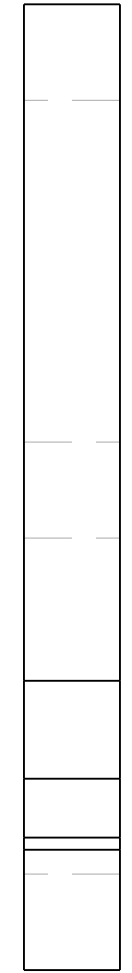
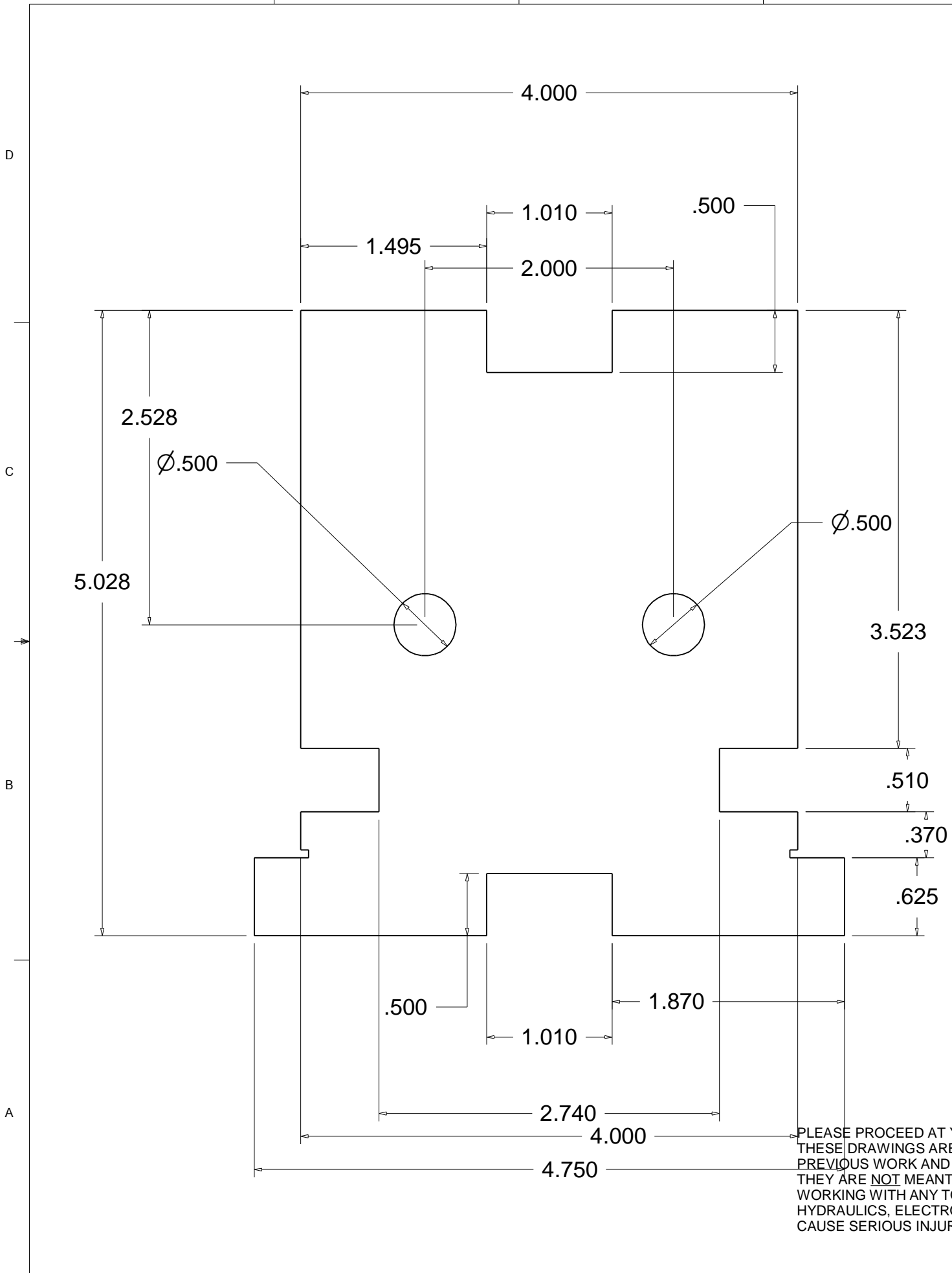

PLEASE PROCEED AT YOUR OWN RISK!
 THESE DRAWINGS ARE MEANT TO DOCUMENT
 PREVIOUS WORK AND PRESENT IDEAS ONLY;
 THEY ARE NOT MEANT TO BE A COMPLETE GUIDE.
 WORKING WITH ANY TOOLS, EQUIPMENT,
 HYDRAULICS, ELECTRONICS, ETC. MAY
 CAUSE SERIOUS INJURY OR DEATH.

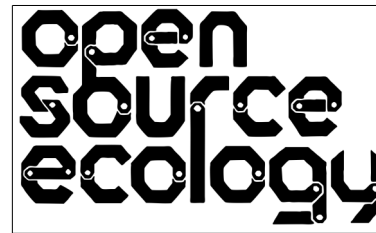

LICENSE INFORMATION
 ALL INFORMATION IS RELEASED UNDER THE OSE
 LICENSE FOR DISTRIBUTIVE ECONOMICS. FOR
 FURTHER INFORMATION GO TO:
 OPENSOURCEECOLOGY.ORG/WIKI/LICENSE

	NAME	DATE
DRAWN	RHB	
CHECKED		
APPR.		
UNLESS OTHERWISE SPECIFIED DIMENSIONS ARE IN INCHES		
ANGLES	.X	.XX
	+-.5	+-.1
		+-.03
		+-.005

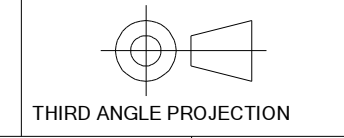

PROJECT:		CEB PRESS 5	
DESCRIPTION:		L-F14	
SIZE	DWG. NO.	REV	
B	01-194-00-3 L-F14		
SCALE: NONE	WEIGHT:		

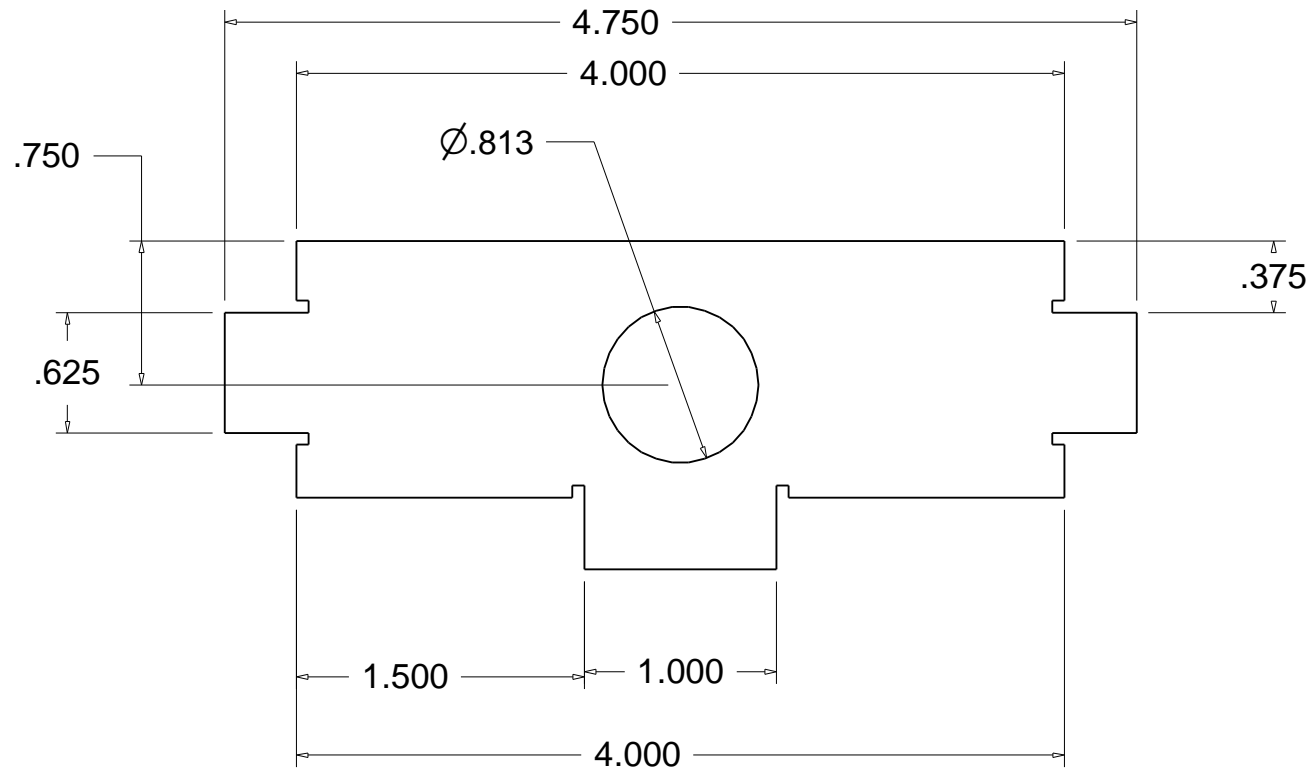
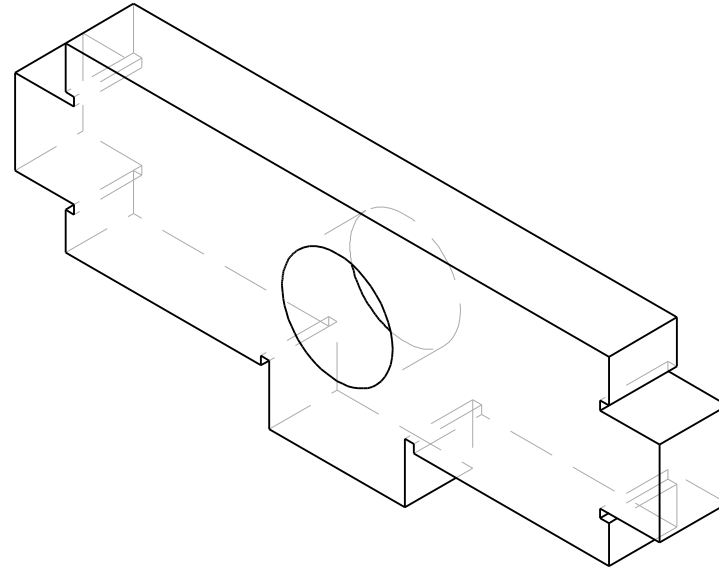

PLEASE PROCEED AT YOUR OWN RISK!
 THESE DRAWINGS ARE MEANT TO DOCUMENT
 PREVIOUS WORK AND PRESENT IDEAS ONLY;
 THEY ARE NOT MEANT TO BE A COMPLETE GUIDE.
 WORKING WITH ANY TOOLS, EQUIPMENT,
 HYDRAULICS, ELECTRONICS, ETC. MAY
 CAUSE SERIOUS INJURY OR DEATH.

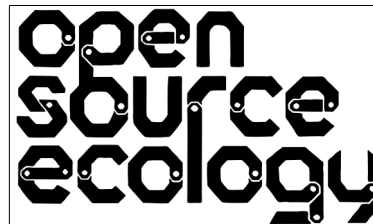

LICENSE INFORMATION
 ALL INFORMATION IS RELEASED UNDER THE OSE
 LICENSE FOR DISTRIBUTIVE ECONOMICS. FOR
 FURTHER INFORMATION GO TO:
 OPENSOURCEECOLOGY.ORG/WIKI/LICENSE

	NAME	DATE
DRAWN	RHB	
CHECKED		
APPR.		
UNLESS OTHERWISE SPECIFIED DIMENSIONS ARE IN INCHES		
ANGLES	.X	.XX
	±.5	±.1
		±.03
		±.005

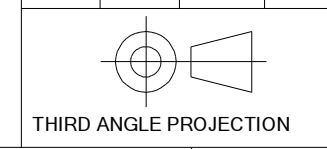

PROJECT:		CEB PRESS 5	
DESCRIPTION:		L-F15	
SIZE	DWG. NO.	REV	
B	01-195-00-3 L-F15		
SCALE: NONE	WEIGHT:		

D

C

B

A

D

C

B

A

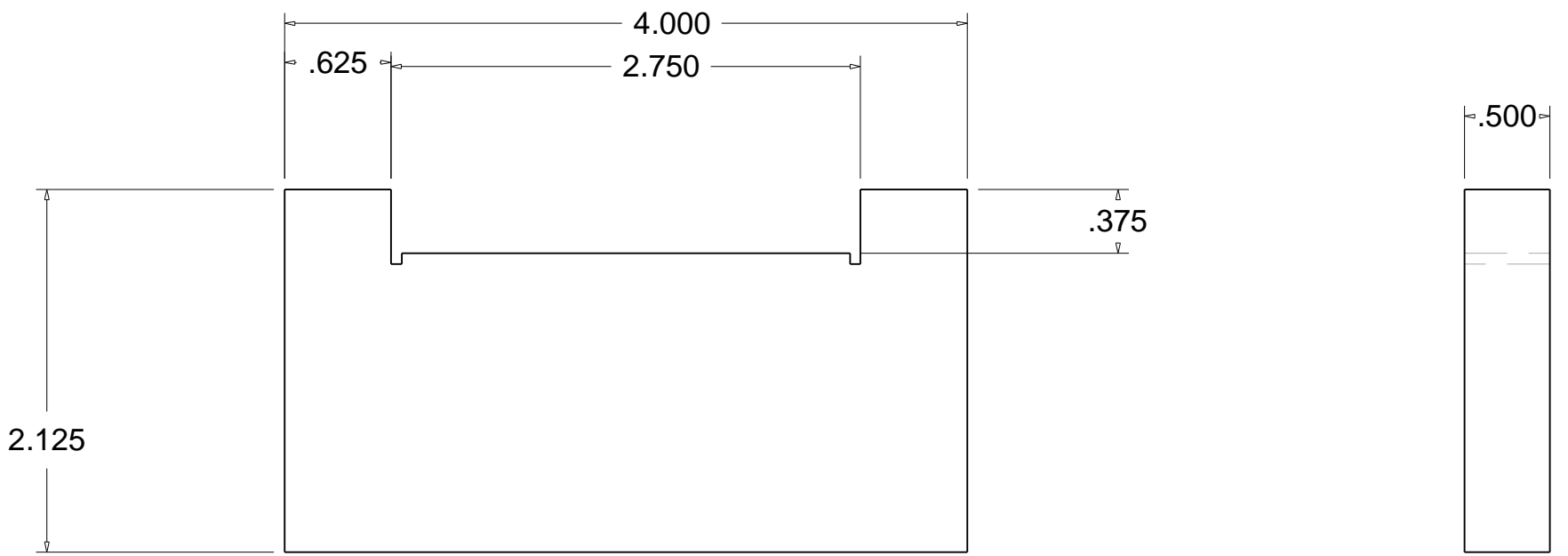
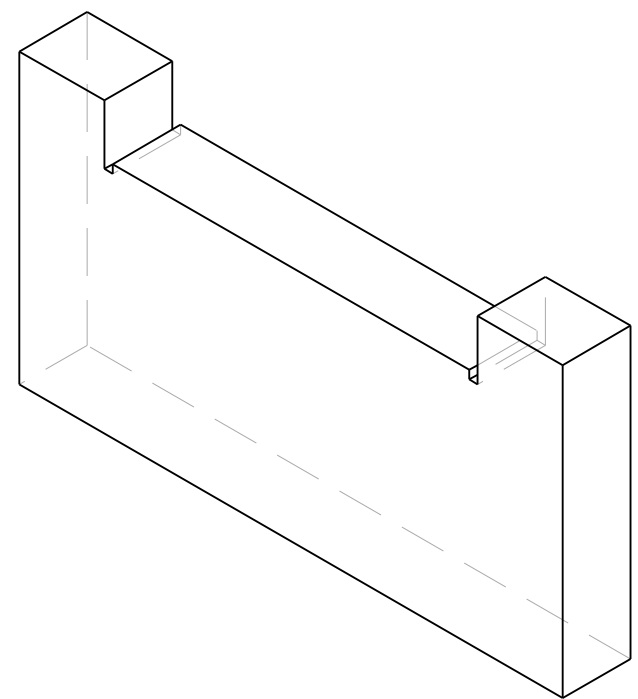
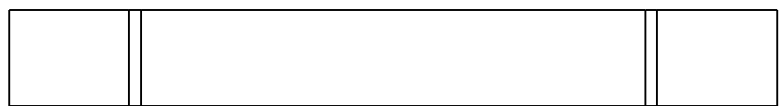

PLEASE PROCEED AT YOUR OWN RISK!
 THESE DRAWINGS ARE MEANT TO DOCUMENT
 PREVIOUS WORK AND PRESENT IDEAS ONLY;
 THEY ARE NOT MEANT TO BE A COMPLETE GUIDE.
 WORKING WITH ANY TOOLS, EQUIPMENT,
 HYDRAULICS, ELECTRONICS, ETC. MAY
 CAUSE SERIOUS INJURY OR DEATH.

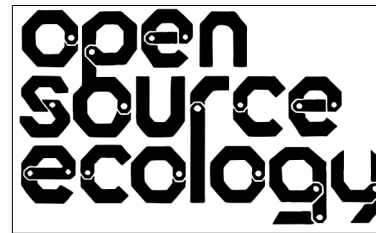

LICENSE INFORMATION
 ALL INFORMATION IS RELEASED UNDER THE OSE
 LICENSE FOR DISTRIBUTIVE ECONOMICS. FOR
 FURTHER INFORMATION GO TO:
 OPENSOURCEECOLOGY.ORG/WIKI/LICENSE

	NAME	DATE
DRAWN	RHB	
CHECKED		
APPR.		
UNLESS OTHERWISE SPECIFIED DIMENSIONS ARE IN INCHES		
ANGLES	.X	.XX
	+-.5	+-.1
		+-.03
		+-.005

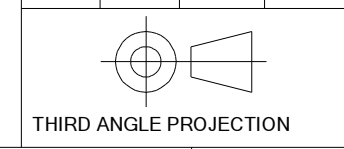

PROJECT:		CEB PRESS 5	
DESCRIPTION:		L-F16	
SIZE	DWG. NO.	REV	
B	01-196-00-3 L-F16		
SCALE: NONE	WEIGHT:		

8 7 6 5 4 3 2 1

8 7 6 5 4 3 2 1

D

D

C

C

B

B

A

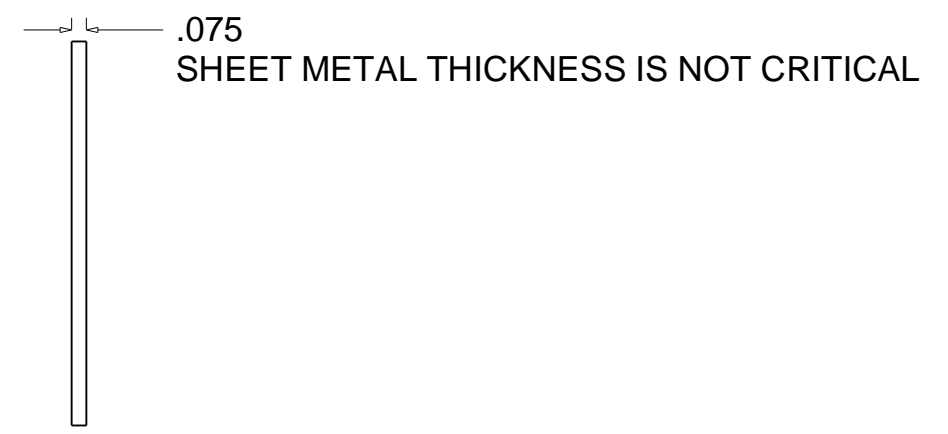
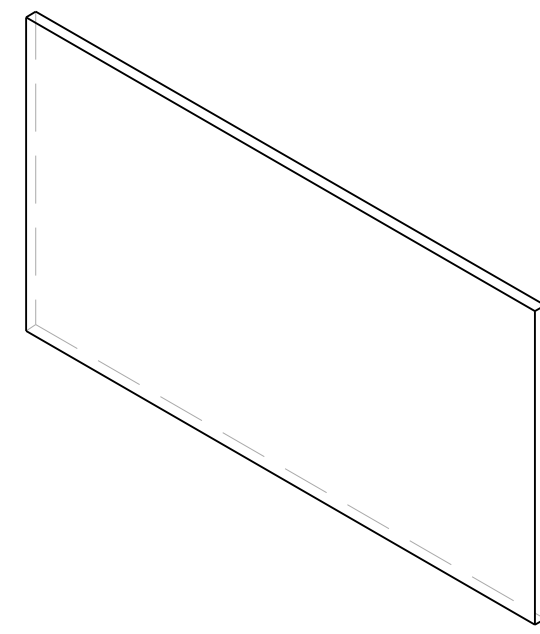
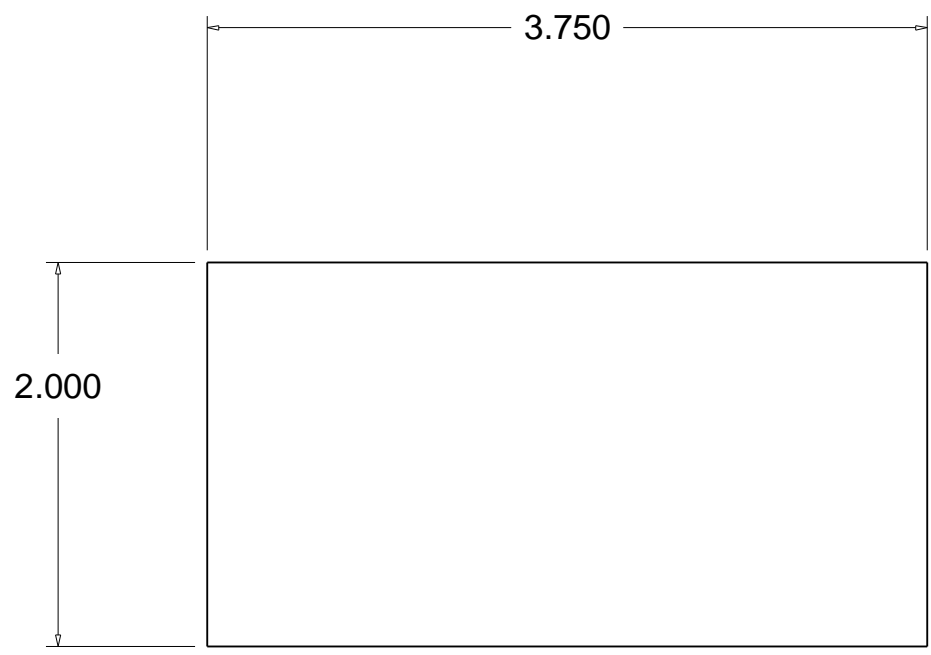

PLEASE PROCEED AT YOUR OWN RISK!
 THESE DRAWINGS ARE MEANT TO DOCUMENT
 PREVIOUS WORK AND PRESENT IDEAS ONLY;
 THEY ARE NOT MEANT TO BE A COMPLETE GUIDE.
 WORKING WITH ANY TOOLS, EQUIPMENT,
 HYDRAULICS, ELECTRONICS, ETC. MAY
 CAUSE SERIOUS INJURY OR DEATH.

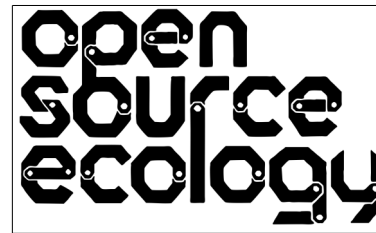

LICENSE INFORMATION
 ALL INFORMATION IS RELEASED UNDER THE OSE
 LICENSE FOR DISTRIBUTIVE ECONOMICS. FOR
 FURTHER INFORMATION GO TO:
 OPENSOURCEECOLOGY.ORG/WIKI/LICENSE

	NAME	DATE		
DRAWN	RHB			
CHECKED				
APPR.				
UNLESS OTHERWISE SPECIFIED DIMENSIONS ARE IN INCHES				
ANGLES	.X	.XX	.XXX	
	+-.5	+-.1	+-.03	+-.005

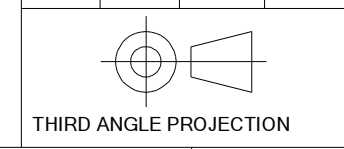

PROJECT: **CEB PRESS 5**

DESCRIPTION:
(14GA APROX.) SHEET METAL BACKING FOR PL

SIZE	DWG. NO.	REV
B	01-199-00-0	

SCALE: NONE WEIGHT:

8 7 6 5 4 3 2 1