

# Linear guide slides

For smooth and extremely accurate positioning

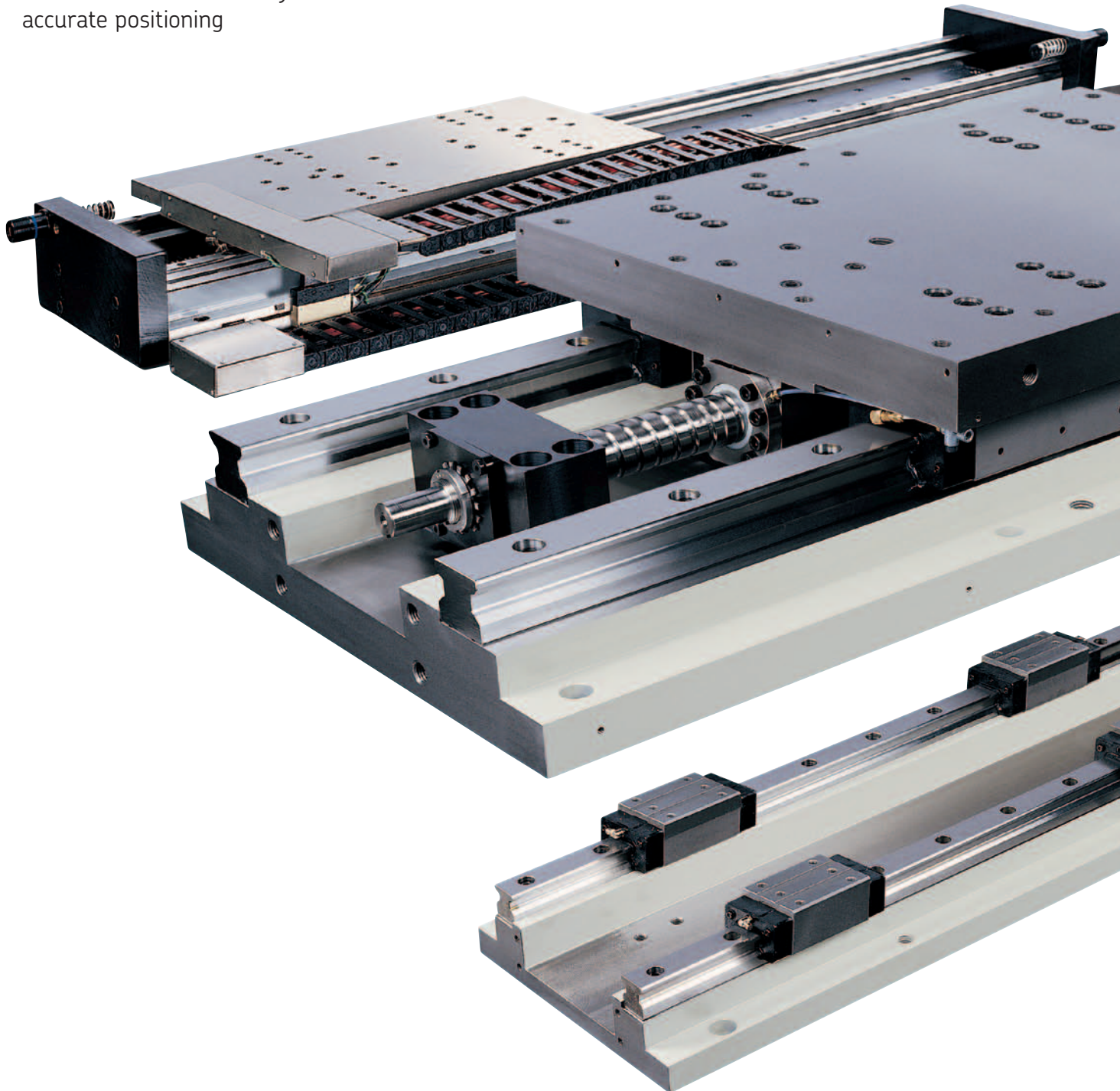

# Complete Gilman USA slide selection

## Linear slides\*\*

### Built-to-order

- Ball or roller styles
- Used for high-precision, high-speed applications
- High-speed drives
- Preloaded bearing

\*\*CAD and 3D files are available upon request

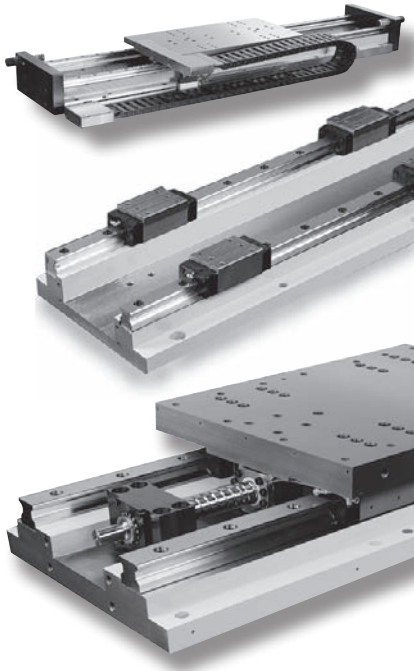

## Hardened steel way slides

### Basic and drive equipped:

See catalog no. 980-613 for specifications

- 5" to 32" widths
- Travel and slide lengths built-to-order
- Several drive styles
- Production cycle durability
- Good for heavy machining application

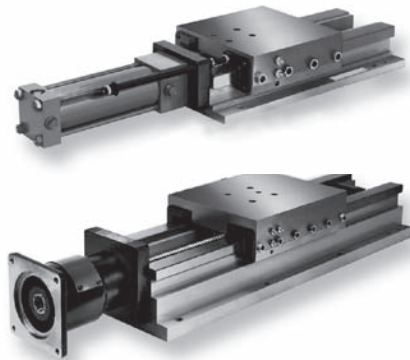

## Dovetail slides

### ND (NextDay) line:

See catalog no. 980-612 for specifications  
(In stock-ships in one business day from order)

- Immediate delivery off-the-shelf product
- In widths of 4", 6", 8", 10"
- Saddle travels of 4", 6", 8", 10"
- Reversible screw drive end and gib side
- Includes holes for mounting and compounding
- Matching angle brackets



L & H tool slide line: Catalog no. 982-612

- 2", 3", 4", 6", 8" widths
- Lead screw drives
- Off-the-shelf product



CP line: Catalog no. 982-612

4", 6", 8" widths

- Air or hydraulic cylinder drives
- Plate mounted

DC line: Catalog no. 982-612

- 2" to 20" widths
- Length and travels built-to-order
- Several drive styles



# Linear guide slides

## Built-to-order for smooth, fast and extremely accurate positioning

Linear guide slides are designed for precise low friction linear movement. These slides can receive loads in any direction and achieve linear movement with extremely high accuracy while providing exceptionally smooth operation. They are ideal for a wide variety of industrial applications such as CNC- and laser-machining centers, drilling machines, grinding machines, material handling equipment, industrial robots, medical and optical equipment and other precision instruments and devices.

Whether your end application is a special machine or an OEM product line, Gilman USA's Grafton, WI plant — along with Gilman USA facilities worldwide — assure you responsive engineering, precision manufacturing and prompt, efficient after-sale service.

## Advantages of linear guide slides

1. Smooth, fast and extremely accurate positioning performance due to low friction.
2. Uniform and low coefficient of friction allows the use of smaller drives and motors.
3. Seals, wipers and covers help protect slides in hostile environments.

Gilman USA linear guide slides are designed for speed and accuracy and at the same time high levels of loading. The recirculating balls or rollers provide a high number of effective contact points, and the preload of the bearing assembly ensures a high level of accuracy. An important characteristic of the linear guide slides is the ability to accept this high loading from any direction.

The high quality of these slides is achieved by precision grinding of rail and bearing mounting surfaces to assure high accuracy. To maintain that high quality, Gilman USA offers metal or fabric covers and coatings for hazardous environments. These coatings resist wear, chemicals and corrosion. Some coatings offer high temperature stability, nonstick surfaces and dry film lubrication.

Gilman USA's facilities, equipment and application engineering assistance help solve your most challenging design problems. Our ISO 18000 quality standards assure that our products have the highest accuracy, reliability, precision and durability.

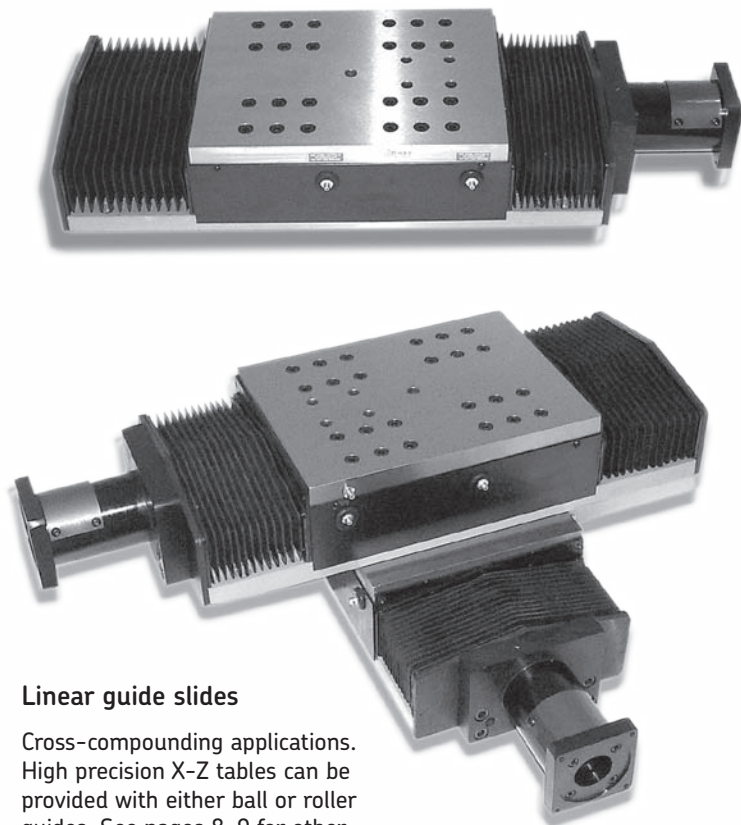

## Linear guide slides

Cross-compounding applications. High precision X-Z tables can be provided with either ball or roller guides. See pages 8–9 for other special applications.

# Linear guideway rolling element selection

## Preload and rigidity

There are applications where linear guide slides are not preloaded, although preload is usually preferred because it eliminates internal clearance and increases rigidity. Balls and rollers used as rolling elements significantly differ in regard to elastic deformation under load.

Elastic deformation of a roller resembles that of a linear spring, while the ball shows characteristics of a non-linear spring. Therefore, the roller generally features a smaller amount of elastic deformation and a higher rigidity than the ball.

The purpose of preload is to reduce elastic deformation caused by the load. This increases the rigidity of the linear guide slide by applying an internal stress in advance to the contact area between the raceways and rolling elements. It may be theorized that the effect of the preload on ball slides is more apparent than on roller slides because of the differences in deformation characteristics. However, excessive preload should be avoided, because it creates various negative effects on the slides such as shorter life, high friction and increased temperatures.

## Friction

The static (start-up) friction of a linear guide slide is much lower than that of a conventional plain slide. Similarly, the difference between static friction and dynamic friction (kinetic friction) is also minimal. This accounts for the ability of linear guide slides to reduce power consumption, lower operating temperatures and increase the overall efficiency of these units.

The frictional resistance of linear guide slides varies with their type, load, traveling speed and lubricant. Generally, lubrication has more effect with light loads and high speed operations, while load has more effect under heavy loads and low speed operation. For sealed guides, it is necessary to add the frictional resistance of the seals which varies with lubricant and the interference fit of the seals. Also, a large moment load or an excessive preload will increase the frictional resistance.

## Lubrication

The primary purpose of lubrication for linear guide slides is to keep raceways, rolling elements and cages from direct metal-to-metal contact, thereby reducing wear and friction.

The performance of linear guide slides is usually influenced by the lubricant and lubrication method. It is important to select an adequate lubricant and lubrication method in accordance with the type of bearing, load, operating speed, etc. However, compared with conventional plain slides, the necessary amount of lubricant for linear guide slides is much smaller, and the interval between lubrication periods can be much longer. This will help reduce maintenance and cost.

Linear guide slides may use either grease or oil for lubrication depending upon the application. For grease lubrication, a lithium-soap base grease (consistency no. 2) is commonly used. For slides operating under heavy load, a grease containing extreme pressure additive is recommended. For oil lubrication, heavier loads require a higher viscosity oil, and a higher operating speed requires lower viscosity.

For operation under heavy loads or high moment loads, a lubricating oil of around 68 cSt may be successfully used. For lighter loads, higher operation speeds, or where extremely smooth movement is required, a lower kinematic viscosity oil of around 13 cSt may be employed.

## Linear roller or ball bearing slide tolerances\*

- Overall height . . . . . =  $\pm .005$  in
- (A) Vertical tracking . . . . . =  $.0003$  in/ft
- (B) Horizontal tracking . . . . . =  $.0003$  in/ft
- (C) Parallelism:  
Saddle to base . . . . . =  $.0005$  in/ft
- (D) Perpendicularity:  
Base end . . . . . =  $.001$  in

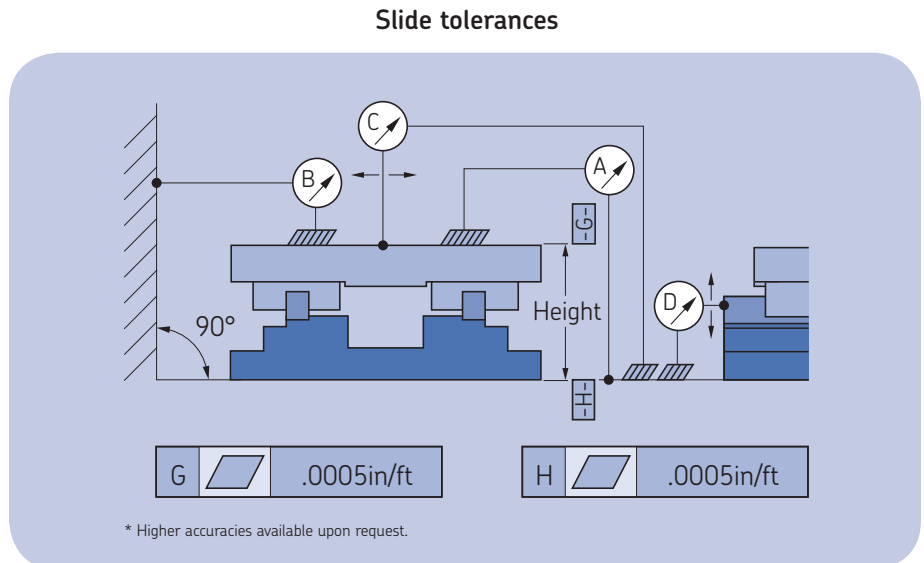

# High precision drive selection

## Ball screw drive design

One type of ball screw drive is available. The metric precision ground ball screw with preloaded nut has a preloaded duplex ball bearing thrust assembly. It is recommended that ball screws and rails be protected from chips, dirt and other contaminants.

*(User must provide stepper or servo motor and specify to Gilman USA the motor frame size.)*

These slides are furnished with recirculating precision bearing element guideway units which track on hardened and precision ground track rails. They are preloaded for maximum rigidity and accuracy. Force required to move the saddle is minimal due to the low coefficient of friction.

## Linear drive design

Linear motor slides are used when high dynamic and precise positioning are required. The linear motors are mainly employed in applications where linear guide slides with conventional rolled or ground ball screw drives have reached their performance limits.

Some typical applications include:

- Precision handling and mounting of moving objects
- Linear control units
- Movements with short stroke and high frequency
- Speed and controlled positioning
- Production, mounting and inspection in electronic and optical industries
- Ultra precise machining
- Automated measuring and testing equipment
- Reprographics

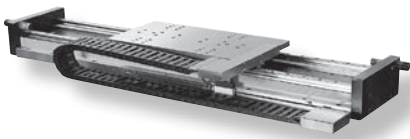

Linear motor drive

## Linear motor drive slide: six basic parts

- 1. Primary unit of the linear motor**  
Current-carrying coil of the motor is integrated into the traveling top saddle.
- 2. Secondary unit of the linear motor**  
Permanent-magnetic or toothed rail, depending on the motor type, integrated into the stationary base.
- 3. Guidance**  
In most linear motor drive slides, the linear guidance consists of two track rail guides, each carrying one or two guideway truck carriages. In applications where limited stroke together with high accuracy and rigidity are required, precision rail guides with crossed roller or needle rollers are used.  
For special applications, linear motor slides can also be equipped with other guideways, e.g. air bearings.
- 4. Sensing head of the linear measuring system**  
The linear measuring system is used for exact determination of the position of the saddle and in part for communication of the motor. Generally, incremental measuring systems with a resolution ranging between  $5\mu\text{m}$  and  $.0005\mu\text{m}$ , depending upon the application, are used.
- 5. Linear measuring system scale**  
In most linear motor tables, an open-type measuring system is incorporated in the slide, the scale being fitted in the slide base.
- 6. Power chain**  
The cables for the primary unit and sensing head are lead to the traveling saddle by means of a power chain.

Linear motor drive slide—Six basic parts

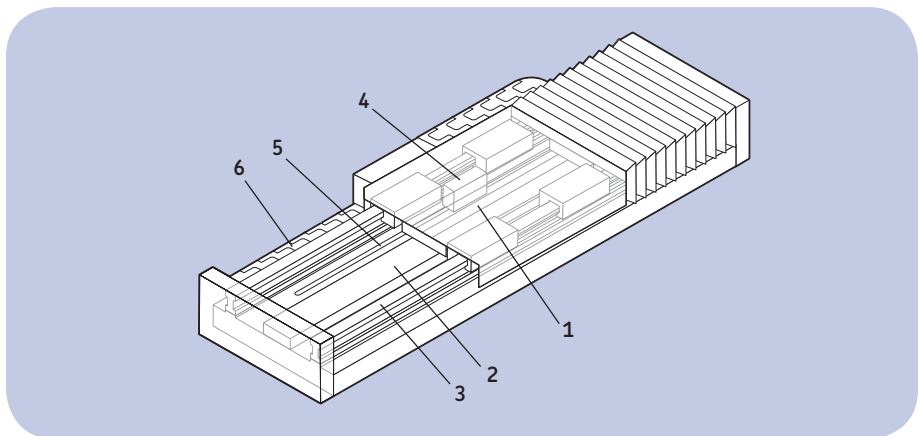

# Linear guide accessories

## Linear guide protection

Gilman USA is very familiar with the heavy-duty machine tool environment and the protection that these precision devices require in the hostile environment of chips, coolant, chemicals, etc. The linear guide slides have several standard features. They are of the wiper design as shown in Figure 1 and the side protection plate as shown in Figure 2.

### Way covers

Accordion way and telescoping way covers are offered as standard options. Gilman USA is very interested in being informed about the environment in which these slides will be applied. Using that information, we will recommend a solution from our wide array of special combinations of covers or coatings which will provide the level of required protection. We will draw from our wide array of special combinations of covers or coatings to ensure the protection required.

- **Accordion way covers**

Recommended for linear guides to protect bearings and screws from dust, dirt, chips and other contaminants.

- **Telescoping way covers**

Collapsible metal covers with durable wipers and guides protect the bearing unit, rail and driver mechanism from contaminants such as chips and dirt. They are available on all linear guides.

### Limit switch side mounts

An oil-tight, plug-in limit switch is available on all linear guides.

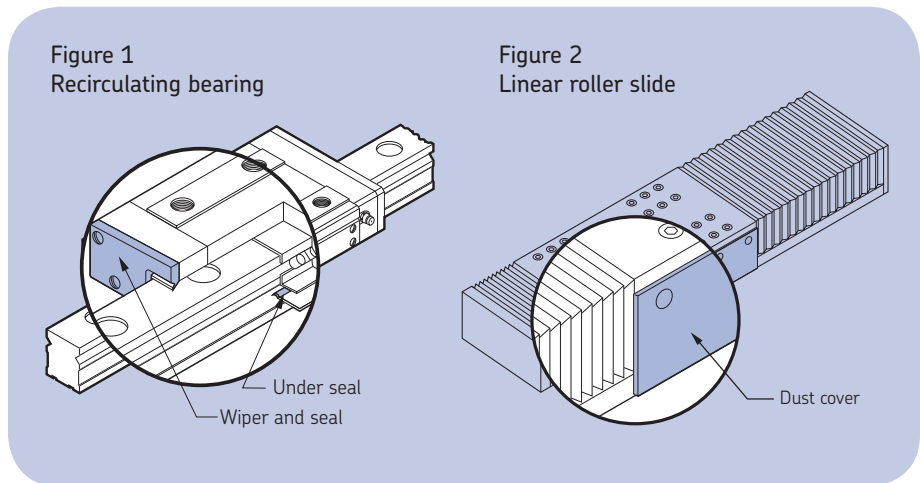

Linear guide protection

### Lubrication system— manual or automatic

Both systems provide a convenient method of supplying a metered quantity of oil to the slide assembly along with the inherent advantages of safety, cleanliness and savings, both in time and lubricant. The manual system uses a pull handle pump lubricator, while the automatic system uses an electric gear motor pump lubricator with a built-in time control that can be set to provide lubrication at proper intervals (specify 115V or 230V). Both lubricators have a 1/2 gallon maximum capacity (depending on slide size). The translucent oil reservoir includes 6 feet of additional tubing so the lubricator can be mounted stationary or on the saddle. The lubricator will be supplied unmounted unless otherwise specified.

### Special coating

Slides, rails and bearings can be treated for certain environmental conditions. These coatings can be corrosion and abrasion resistant, in addition to being a dry film lubricant which reduces friction and wear.

### Mounting holes

Mounting holes can be provided for saddle holes for all linear guides. (User must provide a drawing with hole locations.)

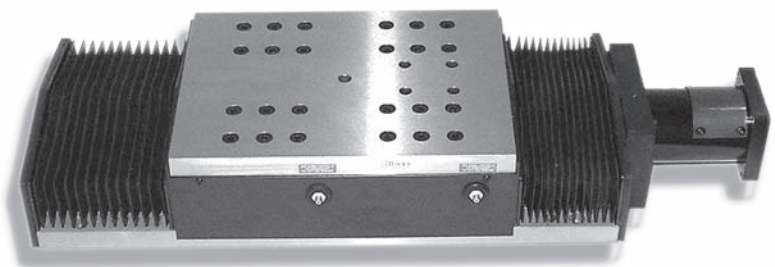

Slide with accordion covers

## Special application examples

### Linear guide slides improve volumetric accuracy 300% for a 5-axis laser machining center

#### Application

Non-thrust, machining operations including automotive and aerospace customers.

#### Challenge

Gilman USA was asked to develop a 3-axis positioning module for laser-machining operations for an automotive and aerospace customer of an OEM machine builder. The previous configuration did not meet the customer's needs. The customer had concerns with the lightweight construction and structural rigidity of the previous roundrail slide components.

#### Solution

Gilman USA initiated a partnership with the customer's engineering team to develop a product that fit their exact needs: machine-tool-quality rigidity in a 3-axis positioning module. This partnership resulted in a new custom-configured design assembled at Gilman USA and utilized standard Gilman USA components. The high degree of rigidity and stability of the final design improved volumetric accuracy by 300 percent.

The ground ballscrews used in the 3-axis custom configuration deliver rapid movements at 1,000 inches per minute. The carefully selected rail structure for the slide component was a key factor in the success of the project. X-section, anti-friction rollers were chosen by Gilman USA for their high vibration damping characteristics. The recirculating rollers of the X-section provide

2.6 times the rigidity of a ball-type guideway of the same size, supplying accuracy needed for this application.

Continuing the partnership approach, Gilman USA helped the customer develop a "just-in-time" business plan that delivers the modules on the exact date specified by the customer. Now, with Gilman USA as an integral part of the business plan, the customer continues to maintain deadlines while maximizing warehouse floor space and increasing overall productivity.

#### Technical specifications

Roller bearing slide tolerances:

- Vertical tracking .0003/ft/axis
- Horizontal tracking .0003/ft/axis
- Perpendicularity .0001
- Flatness .0005/ft/axis

#### Details

The new module provides movements of:

- 34" in the Y axis
- 44" of cross feed
- 34" of infeed

The X-section roller sizes for the design are:

- 25mm for the Y axis
- 45mm for the Z axis
- 65mm for the X axis

Continuing the development of the application, Gilman USA designed a derivative of the basic design that allows 72" of Y travel for a specific application.

The motor mounts and couplers for the Gilman USA custom-designed, 3-axis positioning module for non-thrust machining operations were provided by Gilman USA.

The customer provided the control package.

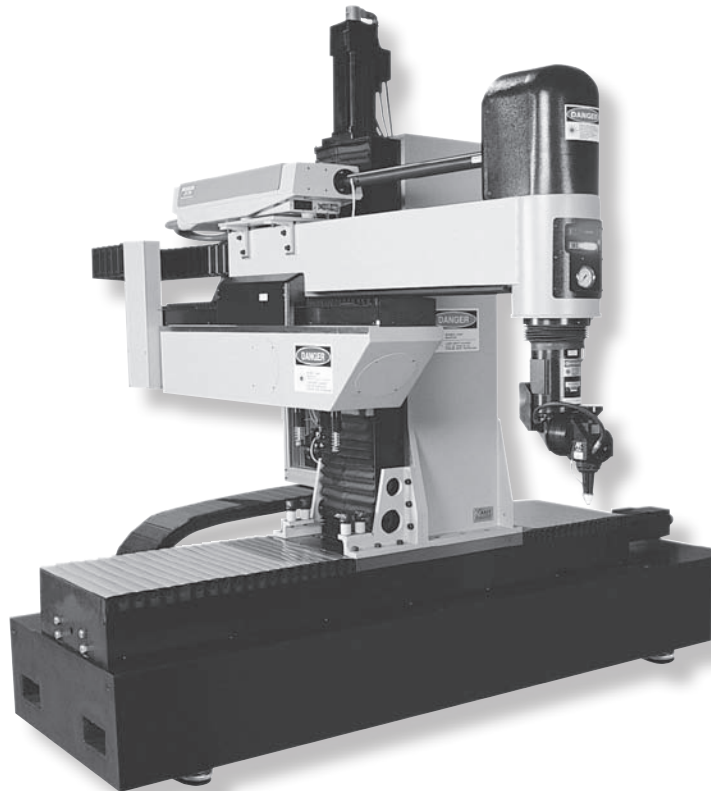

### 5-axis laser machining center

Custom-designed module utilizing standard Gilman USA components increased volumetric accuracy by 300 percent.

# Special application examples

## Pharmaceutical application improves sanitation

Linear guide roller bearing slides are being used to improve sanitation as part of a high speed, high shear, pharmaceutical granulator/mixer.

A leading manufacturer of processing equipment looked to Gilman USA for some modifications to help make the transition from hydraulic to electric power on its pharmaceutical granulator/mixer. In the old design, the integral high shear mixer bowls were raised and lowered by a hydraulic cylinder and pump.

The hydraulic fluid from these parts could possibly contaminate the process room. In the pharmaceutical industry where sterility is of extreme importance, the chance that hydraulic fluid could cause contamination led engineers to look for ways to eliminate hydraulics from the pharmaceutical granulator/mixer. The new linear guide slide needed to be driven by an electric motor and had to support a relatively heavy overhung load plus the compressive load of the rubber seal gasket. Specifically, the manufacturer looked to Gilman USA linear guide roller bearing slides for guiding the vertical travel movement while raising and lowering the mixing bowl.

This particular slide had a saddle width of 7", saddle length of 20", base length of 42" and saddle travel of 20". The motorized linear guide slide was driven by a ball screw with overload coupling and break on input. Gilman USA provided a 5:1 right angle reducer, allowing the motor to run at a nominal speed of 1,750 RPM.

These additional features were necessary to precisely control the speed of the mixer assembly, allowing it to reach the proper velocity for closure of the bowl, while not going so fast that dust from the mixture could escape.

The Gilman USA modifications saved time by making the machine easier to manufacture and also have kept the manufacturer in the forefront of pharmaceutical equipment design. The customer has benefited by the elimination of all hydraulic fluid, pumps and associated cylinders, virtually eliminating any chance that a sterile and expensive pharmaceutical mixture could be contaminated.



Pharmaceutical application

## Cross-compound applications

High precision X-Z tables can be provided with either ball or roller guides.

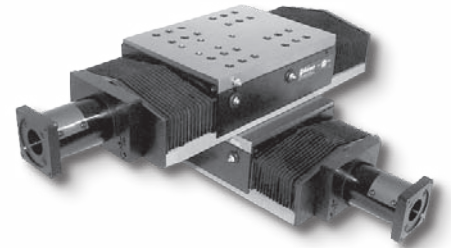



# Request for quote form

By providing some detailed information on application specifications, size, slide type, drive type and accessories, the quoting process can be accelerated. Fill out the form on this page and return it to Gilman USA.

## Request for build-to-order linear guide slide quote worksheet

Company: \_\_\_\_\_

Address: \_\_\_\_\_

\_\_\_\_\_

\_\_\_\_\_

OEM:  Yes  No

Qty(s):			
---------	--	--	--

Rep.: \_\_\_\_\_

### Linear guide slide feature selection

Rolling element selection

Cylindrical roller bearing

Ball bearing

### Slide specifications

Width \_\_\_\_\_ Base length \_\_\_\_\_

Saddle length \_\_\_\_\_

### Drive selection

Metric precision ground ball screw

Linear motor

### Mounting - circle one:

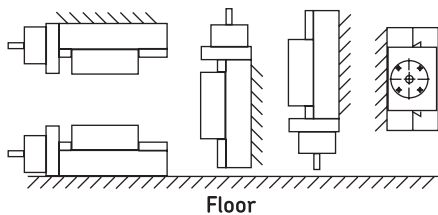

### Accessories:

Accordion way cover

Telescoping way cover

Limit switch side mount

Lubrication system ( manual / automatic )

Special coating

Mounting holes

Quote no. \_\_\_\_\_

Project name \_\_\_\_\_

Contact: \_\_\_\_\_

Phone: \_\_\_\_\_

Fax: \_\_\_\_\_

Budgetary  Firm

Drawing required: \_\_\_\_\_

Due date: \_\_\_\_\_

### Application specifications

Load (W) = \_\_\_\_\_

Inline

Forces (P) = \_\_\_\_\_  Side

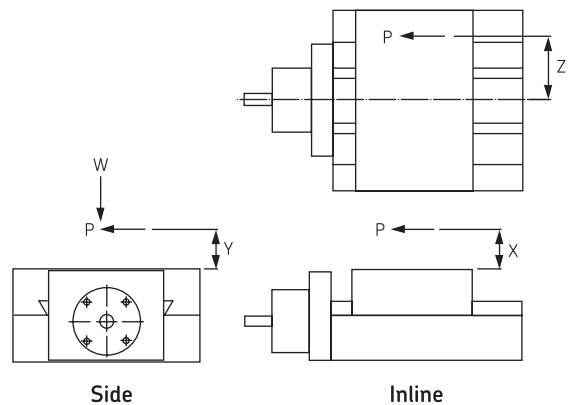

Y = \_\_\_\_\_ X = \_\_\_\_\_ Z = \_\_\_\_\_

Travel required \_\_\_\_\_

Max. traverse rate \_\_\_\_\_

***Include any notes or sketches on separate sheet***

Gilman USA, LLC  
 1230 Cheyenne Avenue • P.O. Box 5 • Grafton, WI 53204  
 Phone: 800-445-6267 • 262-204-2227 • Fax: 262-377-9438  
 E-mail: sales@GilmanUSA.com



**Gilman USA, LLC**

1230 Cheyenne Avenue

P.O. Box 5

Grafton, WI 53204

Telephone: 800-445-6267 or 262-204-2227

Fax: 262-377-9438

e-mail: [sales@GilmanUSA.com](mailto:sales@GilmanUSA.com)

[www.gilmanusa.com](http://www.gilmanusa.com)

The contents of this publication are the copyright of the publisher and may not be reproduced (even extracts) unless prior written permission is granted.

Every care has been taken to ensure the accuracy of the information contained in this publication but no liability can be accepted for any loss or damage whether direct, indirect or consequential arising out of use of the information contained herein.

©2011 Gilman USA, LLC

Version 12/2011

Printed in U.S.A.